



SERVICE MANUAL
RDM SERIES INDEX DRIVES
MODELS
601RDM, 902RDM,
1305RDM, & 1800RDM



"WARNING"

This is a controlled document. It is your responsibility to deliver this information to the end user of the CAMCO indexer.
Failure to deliver this, could result in your liability for injury to the user or damage to the machine.
For copies of this manual call your Customer Service Representative 800/645-5207.

TABLE OF CONTENTS

INTRODUCTION 2

WARNING AND CAUTIONS 2

OIL SEAL REMOVAL 2

SPARE PARTS KIT 2

DISASSEMBLY 3

REMOVAL OF BEARINGS 3

INPUT SHAFT/CAM REMOVAL 4

PRIOR TO REASSEMBLY 4

ASSEMBLY 5

ASSEMBLING INPUT SHAFT 4

ASSEMBLING OUTPUT SHAFT 4

SETTING CAM 4

HOW TO ORDER PARTS 8

EXPLODED PARTS DRAWINGS 9

PARTS LIST 10

180SM REDUCER (601RDM) 14

180SM MOUNTING PARTS LIST 15

CAMCARE® AND CAMPARTS® DESCRIPTIONS 15

INTRODUCTION

This service manual pertains to the disassembly and assembly of CAMCO's RDM Series Index Drives models 80RDM, 601RDM, 902RDM, 1305RDM, & 1800RDM.

The manual is to be used in conjunction with the General Service Manual which describes the lubrication and general maintenance of CAMCO Index Drives.

An exploded view of your specific Index Drive is included in this manual. Also included is a complete Bill of Materials for your convenience in identifying and ordering spare or replacement parts.

Some users of Index Drives have the facilities and trained personnel to accomplish service repair. You must determine the extent to which intricate servicing should be done in your own facility. When in doubt, CAMCO recommends that CAMCO trained servicemen make the repairs.

WARNINGS AND CAUTIONS

Statements in this manual preceded by the words *WARNING* or *CAUTION* and printed in italics are very important. We recommend you take special notice of these during service or repair.

WARNING

Means there is the possibility of personal injury to yourself or others.

CAUTION

Means there is the possibility of damage to the CAMCO unit.

OIL SEAL REMOVAL

The only repair possible without disassembly of the indexer is replacement of oil seals. To remove oil seals, drill a number of holes into the case of the seal. The seal may then be removed with a pointed tool. Be sure to remove all metallic chips created during the drilling of removal holes. A new seal may be installed as outlined in the "Oil Seal Installation Recommendations" section of the "General Service Manual".

SPARE PARTS KIT

CAMCO offers a Spare Parts Kit for all CAMCO index drive models CAMCO builds. These kits include oil seals, bearings, shims and miscellaneous hardware. Camfollowers are sold separately. These are components that will most likely require replacement during repair of your index drive. CAMCO recommends a Spare Parts Kit be purchased and kept on hand prior to the disassembly of your CAMCO drive.

A complete list of components supplied in the Spare Parts Kit can be found in the parts list located in the rear of this manual. The asterisk behind the item number indicates those parts supplied with the Spare Parts Kit. See page 16 for additional spare parts information.

BEFORE STARTING

Before starting the disassembly of your CAMCO unit you should read and review the following instructions. These provide important information on parts and procedures necessary to successfully complete your repair.

Comply with all *Warnings* and *Cautions*.

Read the "Trouble Shooting Guide" section of your "General Service Manual" before disassembling CAMCO units. CAMCO recommends returning defective equipment for inspection and repair whenever possible.

CAMCO uses Loc-Tite to secure all screws and setscrews, If you encounter a fastener that is difficult to remove, apply heat to the screw and remove while still warm.

DISASSEMBLY

1. REMOVE ALL ACCESSORY EQUIPMENT such as clutches, reducers, sprockets, etc. If equipped with a CAMCO R250 Reducer see disassembly instructions manual 0079 pertaining to this reducer prior to removal from the unit.

2. DRAIN OIL AND FLUSH UNIT with flushing solvent. Retain any chips or broken pieces you may find. These may aid in diagnosis.

3. REMOVE BOTTOM COVER.

4. REMOVAL OF OUTPUT SHAFT.

- A. Remove the capscrews holding the large output bearing retaining ring.
- B. Drive the two dowel pins through the retaining ring and housing with an undersize punch.
- C. Lift the output/follower wheel from the housing. Save the retaining ring shims for later installation.



Fig.1 Output shaft removal

5. FOLLOWER INSPECTION.

Inspect followers for damage or radial looseness. It should not exceed .001 inch. Do not confuse radial looseness with axial endplay. Endplay will be from .03" to .06" as a normal condition. If it exceeds .06 it may require replacement.

NOTE: Generally, followers are replaced as added insurance against failure later.

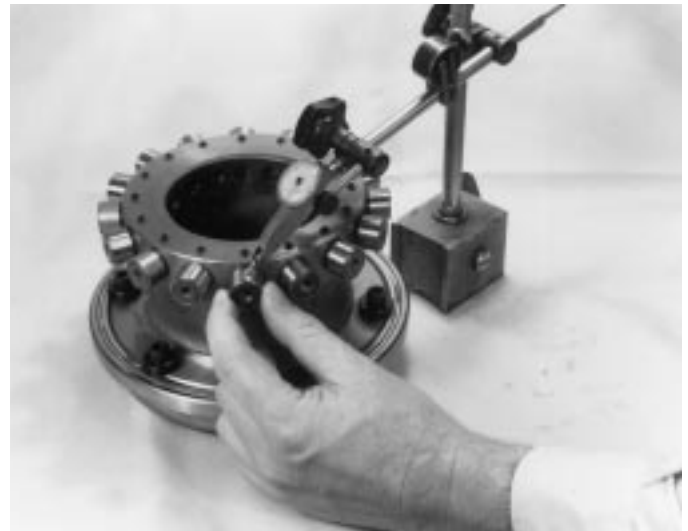

Fig.2 Inspecting for radial looseness

6. FOLLOWER REMOVAL.

Followers can be removed at this stage.

- A. Remove the setscrews. Apply heat to the setscrews holding the follower studs and remove while still warm.
- B. Threaded holes have been provided in the ends of the follower for ease of removal. Use a slide hammer or a simple self-made pull tool. The self-made pull tool consists of a short piece of round tubing, large enough to clear the follower diameter and a small flat bar with a clearance hole large enough to insert a capscrew of equal thread size as the follower pull hole. Slip the tube over the follower, place the bar over the tube and thread a capscrew into the follower. Tightening the capscrew will remove the follower.



Fig.3 Follower pull tools.



Fig.3A Follower pull tools in use.



Fig .4. Removing output bearing.

7. CHECK THE FOLLOWER HOLES.

Check the follower holes for roundness. These holes may be worn out due to overloads. The holes should be round to within .0005 to permit reuse of the follower wheel.

8. OUTPUT SHAFT DISASSEMBLY.

- A. Turn output shaft over and tap on back side of retaining ring, alternating from side to side until the retaining ring is free of the output/follower wheel.
- B. Remove the main bearing from the output/follower wheel.
 - 1) Remove the bearing retaining capscrews and washers.
 - 2) From the top side of the output, place a small aluminum bar against the inside face of the bearing and tap with a hammer. Alternate from side to side to prevent cocking until the bearing is free of the output/follower wheel.

9. INPUT SHAFT / CAM REMOVAL.

NOTE: The output shaft must be removed prior to input shaft removal.

- A. Rotate the input shaft and inspect all parts for damage or wear. Endplay in the input shaft is not permissible.
- B. Remove all input bearing cartridge capscrews.
- C. Tap on the end of the input shaft to drive the opposite cartridge from the housing. Then drive the shaft in the opposite direction for removal of the other cartridge.

NOTE: Keep shims with their respective cartridges. You will be asked to reinstall or replace with the same shim thickness during assembly.

- D. Remove the input shaft/cam assembly from the housing.



Fig. 5 Removing input shaft assembly

- E. Use a wheel puller to remove the bearing cones from the input shaft.
- F. Remove the cam locknuts with a spanner wrench. Be sure to bend the washer locking tangs away from the nut prior to removal, if applicable.
- G. Use an arbor press to remove the cam from the input shaft. Use caution not to damage the parts. If an arbor press is not available you may drive the shaft out by tapping on the end of the shaft with a soft face.



Fig. 6 Pressing out camshaft

10. REMOVE THE INPUT BEARING CUPS

Remove the input bearing cups from the cartridges with a pulley puller, by prying or by drilling and tapping for jack screws.

ASSEMBLY

PRIOR TO REASSEMBLY

Clean and deburr all parts before reassembly.

Follow tightening torque and Loc-Tite recommendations as outlined in the "General Service Manual".

1. Use an arbor to press the bearing cups into the cartridges. Coat the outside of the cup and the bore of the cartridge with an anti-seize lubricant prior to pressing. Fill cavity of cartridges with bearing grease recommended in the "General Service Manual".

2. ASSEMBLING INPUT SHAFT.

- A. Use arbor to press the cam onto the shaft. Be sure key is installed into the shaft first. Apply anti-sieze lubricant to shaft and bore prior to pressing. If a heat gun is available it is recommended that the bore of the cam be heated prior to pressing.
- B. Use a spanner wrench to install the cam locknuts. Adjust nuts to center cam on shaft.



Fig.7. Centering cam on shaft

- C. Use an arbor to press bearing cones onto shaft. Coat shaft and bearing bore with anti-sieze lubricant prior to pressing. If a heat gun is available it is recommended that the bore of the bearing be heated prior to pressing.
- D. Install the input cartridges. Be sure to install the same exact shims or equivalent height as was removed in disassembly Step 9C.
- E. Tighten cartridge mounting screws.
- F. If endplay exists remove an equal amount of shims from each side until there is a small amount of drag from preloading the bearings. In rare instances it may be necessary to re-machine the cartridges if all shims have been removed and endplay still exists.

3. ASSEMBLING OUTPUT SHAFT.

- A. Install the large bearing cones on the output shaft. Coat the bore of the cone with an anti-sieze lubricant prior to installation. Tap in place with a hammer and aluminum bar. Place the bar against the inner face and tap with hammer. Alternate from side to side to avoid binding until the bearing is fully seated on the output/follower wheel.

- B. Install the bearing retainer capscrews and washers. Use torque and Loc-Tite recommendations from the "General Service Manual".
- C. Install new followers with an arbor press.

CAUTION: Be sure to press the followers in straight as damage to the follower and wheel could occur if improperly aligned during installation. Be sure that the notches are aligned with the setscrew holes.

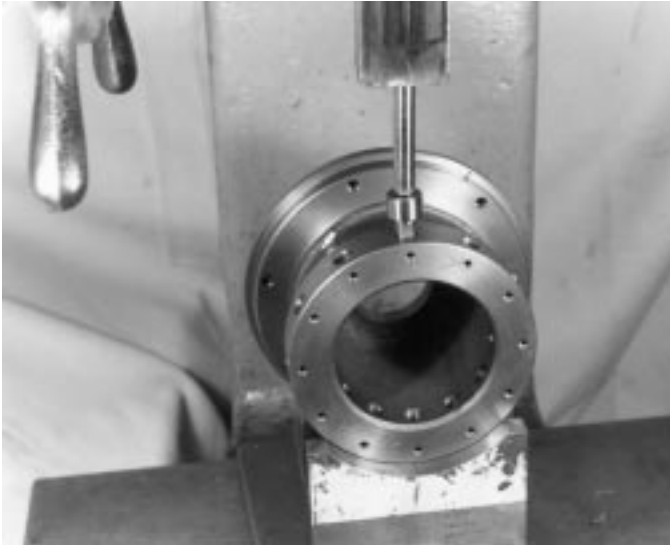

Fig. 8 Pressing in new followers

- D. Install the setscrews with double-notch followers, the cone point setscrews lock into the "V" notch. The cup point setscrews lock against the flat single-notch followers, use an oval point setscrew. Be sure to use Loc-tite thread locking liquid as recommended in the "General Service Manual".
- E. Coat the inside of the bearing retainer ring and the outside of the main output bearing with anti-sieze lubricant. Place the bearing retainer ring over the output from the topside of the output/follower wheel and tap, alternating from side to side until the retainer is fully seated on the bearing.
- F. Replace the shims removed in disassembly step 4C.
- G. Place cam in dwell position, keyway pointing rearward.
- H. Insert output/follower wheel into housing with dowel holes in housing in line with retainer.
- I. Loosely install the bearing retainer capscrews.
- J. Install only one of the dowel pins through the retainer ring into the housing.

4. SETTING THE CAM.

CAUTION: This mechanism is designed to operate with adjacent followers in close contact along their entire width, unless this condition is achieved by proper installation, the mechanism will not transmit its rated load, and serious damage to the cam and output shaft will occur.

- A. Place the unit on end or its side so both the output side and the bottom opening are accessible.
- B. Place the cam in dwell, keyway facing rearward.
- C. While pivoting on the one dowel pin, rotate the output towards the input shaft as much as the clearance holes for the mounting capscrews will allow.
- D. Shift the cam axially until two adjacent followers are in full contact with the cam rib. This will also require adjustment of the output retaining ring along with axial adjustment of the cam.
 - 1) If there is a gap at the root of the follower the cam should be shifted toward the follower.
 - 2) If there is a gap at the tip of the follower the cam should be shifted away from the follower.

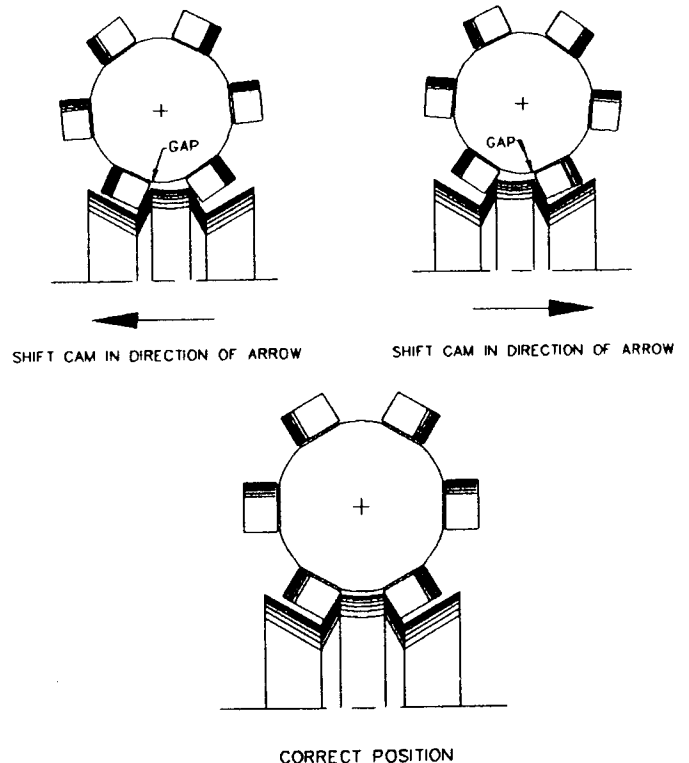

Fig.9 Shifting cam for proper alignment

- E. Apply "Prussian Blue" to entire cam track.
- F. Rotate the camshaft slowly with a small handcrank to ensure that:
 - 1) Both rollers are in contact with the cam rib in dwell. Look for uniform blueing pattern.
 - 2) The follower is free when it is in the center of the crossover track.
 - 3) You do not encounter unusual resistance in motion. The blueing pattern should be fairly uniform from side to side during motion. If a patch of blueing is worn off the outside of the cam rib on one side of the cam and not the other, shift the cam a .002 to .005 inches in the direction of the worn side. Do not overshift the cam or knocking will occur.
 - 4) The cam blueing should never be worn off the lead-in or exit edges of the cam ribs. This would indicate that the cam is not adjusted properly.
 - 5) There should be no looseness in any dwell. If there is looseness adjust the output bearing retainer to slightly preload the loosest dwell.
- G. Tighten the locknuts and secure with Loc-Tite #242 as specified in the "General Service Manual". If lockwashers are used on your model, bend the tangs over the nut to insure locking.

- H. Tighten the output retaining ring capscrews.
- I. Drill and ream the remaining hole in the output retaining ring to accept the next larger dowel pin. Install new dowel.

- 8. REINSTALL THE BOTTOM COVER. Apply "General Electric Silicone Rubber RTV-6" to the sealing surfaces of the housing and cover. Place the gasket on the housing and place cover over the gasket. Install and tighten capscrews.
- 9. GREASE PACK THE MAIN OUTPUT BEARING with lubricant specified in the "General Service Manual".
- 10. INSTALL NEW OIL SEALS as described in the "General Service Manual".
- 11. FILL THE INDEX WITH THE RECOMMENDED OIL to level indicator. See "General Service Manual". Too high an oil level will cause no damage. Too low a level may result in unit failure.



Figure 10 Tighten cam locknuts

HOW TO ORDER PARTS

Please refer to parts list shown in this manual. This parts list is for a standard Index Drive. If you feel your drive is nonstandard or you are in doubt you should contact CAMCO Customer Service at (847) 459-5200 and request a Bill of Materials for your specific unit based on serial number. CAMCO maintains records on all units for a period of ten years.

You may order parts per the standard Bill of Material even if your unit is nonstandard. CAMCO's order entry department will review the closed order file based on the following information and supply you with the correct part.

REQUIRED INFORMATION

1. Original purchase order number (if available)
2. Customer name (original purchaser of drive)
3. Model number (located on name plate)
4. Serial number (located on name plate)
5. Approximate date of purchase.

TO ORDER PARTS contact CAMCO "Order Entry Department" Wheeling, Illinois

Phone (847) 459-5200 or Fax (847) 459-3064

- A. Describe the parts required and the 14 digit part number as listed in the Standard Bill of Materials or a Special Bill of Materials pertaining to your unit. State if you are using a Standard or Specific bill of material.
- B. Give as much of the above required information as possible.

ON WARRANTY

CAMCO will send replacement parts freight prepaid via most practical mean.

CAMCO will issue a "Returned Material Authorization Number" (RMA#) for the return of defective parts for inspection. CAMCO will bill customer for repair parts. When inspection of returned parts has been completed and determined to be covered under warranty, CAMCO will issue a credit to the customer for the repair parts and freight charges. Camco standard warranty is defined in Camco's "Terms and Conditions".

ON NON-WARRANTY

Replacement or spare parts, with approved credit, are F.O.B. our plant Wheeling, Illinois.

601RDM, 902RDM, 1305RDM & 1800RDM

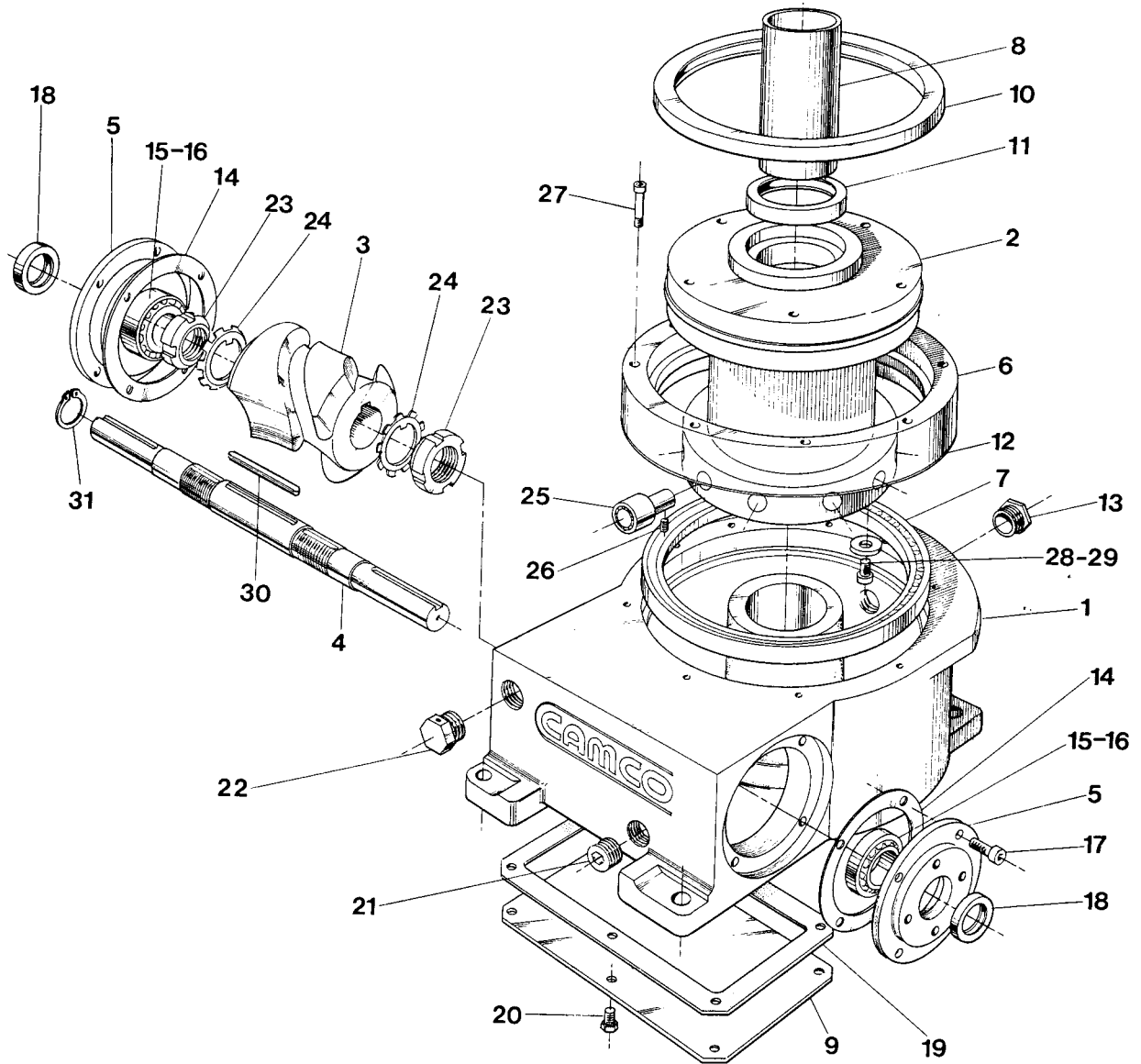

PARTS LIST FOR 601RDM INDEX DRIVE (STANDARD CONFIGURATION)

<u>ITEM NO.</u>	<u>PART NUMBER</u>	<u>DESCRIPTION</u>
1	51D51194001002	Housing
2	51C38781014012	Follower wheel 12 hole
.....	51C38781024016	Follower wheel 16 hole
3	_____	Cam, (specify number of stops and Index time, contact camco for Assistance, order in matched sets)
.....	_____	_____
4	51C37687007002	Input shaft (w/o red or w/180SM)
.....	51C52700007002	Input shaft (for 7200C)
.....	51C65588007002	Input shaft (for 180SM/180-IOC)
5	51C51099003001	Cartridge, input
6	51C37690000000	Bearing retainer
7	86A27251000000	Bearing
8	51A52302000000	Tube,through hole
9	51B52264000000	Cover, bottom
10*	84D07329780000	Oil seal C/R 64993
11*	84D07329340000	Oil seal C/R 19745
12*	51B27248018800	Shim, .002
*	51B27248028800	Shim, .005
*	51B27248038800	Shim, .010
*	51B27248048800	Shim, .015
13	95A33001010000	Sight plug 3/8-18
14*	51B52278018800	Shim, .002
*	51B52278028800	Shim, .005
*	51B52278038800	Shim, .010
15*	86D07328120021	Bearing cone LM11949
*	86D07328070021	Bearing cone A6075
*	86D07328210021	Bearing cone 17119
16*	86D07328120022	Bearing cup LM11910
*	86D07328070022	Bearing cup A6157
*	86D07328210022	Bearing cup 17244
17	95A26000390000	S.H.C.S. 1/4-20 x 5/8
18*	84D07329080000	Oil seal C/R 7443
*	84D07329180000	Oil seal C/R11878
19	_____	Not used on 601RDM
20	95A26003140000	B.H.C.S. 10-24 x 3/8
21	95A33003010000	Magnetic plug
22	95A33000010000	Air vent 3/8-18
23	95A26009050000	Locknut
24	95A26010050000	Lockwasher
25	82C33150020003	Cam follower
26*	95A26012070000	S.S.S. oval 10-24 x 3/8
27	95A26000430000	S.H.C.S. 1/4-20 x 1 1/4
28	95A26000530000	S.H.C.S. .31 x .62
29	99A27266000000	Flat washer
30	025K200	Key .250 SQ. X 2.00
31	_____	Not used on 601RDM
32	51C39452000000	Stationary output shaft
33*	84A54015000000	O-ring 2-234
34	_____	Not used on 601RDM
35	26B01051049000	Spacer output
36*	99A44547070000	Service manual for RDM
37*	99A44547010000	General service manual

* Indicates parts supplied with Spare Parts Kit #SPK601RDM

PARTS LIST FOR 902 RDM INDEX DRIVE (STANDARD CONFIGURATION)

<u>ITEM NO.</u>	<u>PART NUMBER</u>	<u>DESCRIPTION</u>
1	56D59101001002	Housing Standard
	56C44335001002	Housing W/ Center Post/Tooling
	56D41866001002	Housing W/PI Mounting Holes
	56C38728001002	Housing W/Stationary Center Post
2	56C38768014012	Follower Wheel 12 Hole H32
	56C38768024016	Follower Wheel 16 Hole H32
3	_____	Cam, (Specify Number Of Stops And Index Time, Contact Camco For Assistance, Order In Matched Sets)
4	56C38713007002	Input Shaft (No Reducer)
	83D36422007002	Input Shaft (For R250)
	56C39230007002	Input Shaft (For 25GED)
	56C63374007002	Input Shaft (For R225)
	56D63506007002	Input Shaft (For R225 W/IOC)
	56C51857007002	Input Shaft (For R260)
	56D61647007002	Input Shaft (For R260 W/ 20 DHL)
	83D47856007002	Input Shaft (For R250 Dual C/L)
5	56C36428003021	Cartridge Open (Inp)
6	56C23495009300	Retainer Bearing
7	86A24320000000	Bearing
8	_____	Not Used On 902RDM
9	56B35134009600	Cover, Bottom
10*	84D07329860000	Oil Seal C/R 95052
11*	84D07329500000	Oil Seal C/R 27280
12*	56B26168018800	Shim, .002
*	56B26168028800	Shim, .005
*	56B26168038800	Shim, .010
13	95A33001010000	Sight Plug 3/8-18
14*	56C36423018800	Shim, .002
*	56C36423028800	Shim, .005
*	50B06038028800	Shim, .005
*	56C36423038800	Shim, .010
15*	86A22882000021	Bearing Cone Lm67049
16*	86A22882000022	Bearing Cup Lm67010
17	95A26000390000	S.H.C.S. 1/4-20 X 5/8
18	84D07329180000	Oil Seal C/R11878
19	_____	Not Used On 902RDM
20	95A26015220000	H.H.C.S. 10-24 X 1/2
21	95A33003010000	Magnetic Plug
22	95A33000010000	Air Vent 3/8-18
23	95A26009070000	Locknut
	95A26009080000	Locknut
24	_____	Not Used On 902RDM
25	82C33150040003	Cam Follower
26*	95A26012130000	S.S.S. Oval Pt 1/4-20 X 3/8
27	95A26000580000	S.H.C.S. 5/16-18 X 1 1/2
28	95A26016450000	S.H.C.S. 3/8-24 X 3/4
29	99A24322000000	Heavy Duty Flat Washer
30	031K300	Key .3125 Sq. X 3
31	95A33033170000	Retaining Ring 5160-125
32	56L26076009540	Stationary Output Shaft
	56C58129009540	Stationary Output Shaft For 10.50 Mounting
33*	99A26350000000	O Ring Parker #236
*	84A56357000000	O-Ring 2-155 Buna N
*	84A36425000000	O-Ring Parker #-136
34	56C63181009100	Mounting Plate (For R225)
	56D36427003021	Mounting Plate (For R250)
	80C39416009100	Mounting Plate (For Red)
	80C51855000000	Mounting Plate (For R260)
35	_____	Not Used On 902 RDM
36*	99A44547070000	Service Manual-RDM
37*	99A44547010000	General Service Manual

* Indicates parts supplied with Spare Parts Kit #SPK901RDM

PARTS LIST FOR 1305RDM INDEX DRIVE (STANDARD CONFIGURATION)

<u>ITEM NO.</u>	<u>PART NUMBER</u>	<u>DESCRIPTION</u>
1	57G41046001002	Housing
2	57C42229014012	Follower Wheel 12 Hole
.....	57C42229024016	Follower Wheel 16 Hole
3	_____	Cam, (Specify Number Of Stops And
.....		Index Time, Contact Camco For
.....		Assistance, Order In Matched Sets)
4	57D40902007002	Input Shaft (W/O Reducer)
.....	57D42389007002	Input Shaft (For 7350C, 30DHL)
.....	57D43552007002	Input Shaft (For 7300C, 30DHL)
.....	57D43807007002	Input Shaft (For 7350C)
5	57C40930003002	Cartridge, Input
6	57D42236000000	Retainer Bearing
7	86A42226000000	Bearing
8	_____	Do Not Use On 1305RDM
9	57B40937000000	Cover, Bottom
10*	84A41047000000	Oil Seal C/R 1450242
11*	84A41048000000	Oil Seal C/R 57510
12*	57B42238018800	Shim .002
*	57B42238028800	Shim .005
*	57B42238038800	Shim .010
13	95A33001020000	Sight Plug 1/2-14
14*	57B40958018800	Shim .002
*	57B40958028800	Shim .005
*	57B40958038800	Shim .010
15*	86D07328460021	Bearing Cone 45287
16*	86D07328460022	Bearing Cup 45220
17	95A26000700000	S.H.C.S. 3/8-16 X 7/8
18*	84D07329380000	Oil Seal C/R 21336
19	57B40938000000	Gasket, Bottom Cover
20	95A26002140000	HHCS 5/16-18 X 5/8
21	95A33003020000	Magnetic Plug
22	95A33000020000	Air Vent 1/2-14
23	95A26009140000	Locknut
24	95A41521140000	Lockwasher
25	82C10457060003	Cam Follower
26*	95A26005450000	S.S.S. Cup 1/4-20 X 1/2
*	95A26006210000	S.S.S. Cone 1/4-20 X 1/2
27	95A26001100000	S.H.C.S. 1/2-13 X 2 1/4
28	95A26001050000	S.H.C.S. 1/2-13 X 1
29	95A26021260000	Flat Washer 6002
30	062K475	Key .625 Sq. X 4.75
31	_____	Not Used On 1305RDM
32	57C41192000000	Stationary Output Shaft
33	_____	Not Used On 1305RDM
34	80C44620000000	Mounting Plate (For 7300C)
.....	80D44630000000	Mounting Plate (For 7350C)
35	_____	Not Used On 1305RDM
36*	99A44547070000	Service Manual-RDM
37*	99A44547010000	General Service Manual

* Indicates parts supplied with Spare Parts Kit #SPK1305RDM

PARTS LIST FOR 1800RDM INDEX DRIVE (STANDARD CONFIGURATION)

<u>ITEM NO.</u>	<u>PART NUMBER</u>	<u>DESCRIPTION</u>
1	H2G48562001002	Housing
2	H2D48544014012	Follower Wheel 12 Hole
.....	H2D48544024016	Follower Wheel 16 Hole
3	_____	Cam, (Specify Number Of Stops And
.....		Index Time, Contact Camco For
.....		Assistance, Order In Matched Sets)
4	H2D48524007002	Input Shaft (W/O Red)
.....	H2D48525007002	Input (Shaft For 7400C)
.....	H2D48731007002	Input Shaft (For 7500C)
.....	H2D50672007002	Input Shaft (For 7400C/400-IOC)
.....	H2D55014007002	Input Shaft (For 7500C/500-IOC)
5	H2C64443003002	Cartridge Input
6	H2D64003000000	Bearing Retainer
8	_____	Not Used On 1800RDM
9	56B35134009600	Cover Bottom
10*	84A48576000000	Oil Seal 2050252
11*	84A48577000000	Oil Seal 75030
12*	H2B48578018800	Shim, .002
*	H2B48578028800	Shim, .005
*	H2B48578038800	Shim, .010
13	95A33001030000	Sight Plug 3/4-14
14*	H2B48579018800	Shim, .002
*	H2B48579028800	Shim, .005
*	H2B48579038800	Shim, .010
15*	86D07328600021	Bearing Cone 566
16*	86D07328600022	Bearing Cup 563
17	95A26000710000	S.H.C.S. 3/8-16 X1
18*	84D07329510000	Oil Seal C/R 27295
19	H2C48539000000	Gasket, Cover 1800RDM
20	95A26003140000	B.H.C.S. 10-24 X 3/8
21	95A33003060000	Magnetic Plug
22	95A33000030000	Air Vent 3/4-14
23	95A26009160000	Locknut Pn-16
24	95A41521160000	Lockwasher Wh-16
25	82C10457080003	Cam Follower Cfh 292
26*	95A26005470000	S.S.S. Cup Pt 1/4-20 X 3/4
27	95A26001300000	S.H.C.S. 5/8-11 X 2 1/2
28	95A26001260000	S.H.C.S..5/8-11 X 1 1/2
29	95A26021270000	Washer Flat 6003
30	075K650	Key .750 Sq X 6.50 Lg
31	H2D64002000000	Retaining Ring, 1800RDM Mach
32	H2C48734000000	Stationary Output Shaft
33	_____	Not Used On 1800RDM
34	80D48720000000	Mounting Plate (For 7400C)
.....	80C48730009100	Mounting Plate (For 7500C)
35	_____	Not Used On 1800RDM
36*	99A44547070000	Service Manual-RDM
37*	99A44547010000	General Service Manual

* Indicates parts supplied with Spare Parts Kit #SPK1800RDM

180SM REDUCER

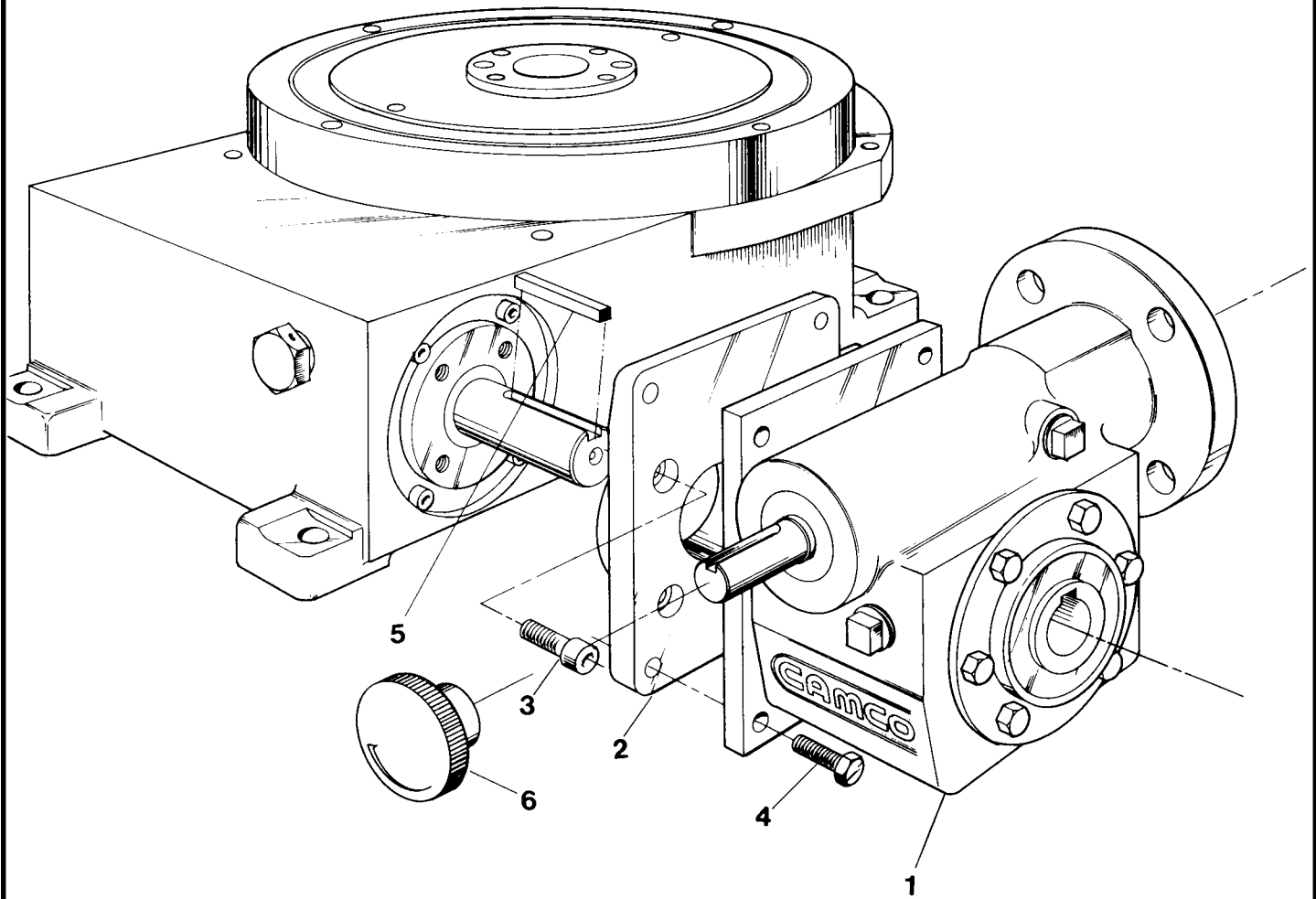

PARTS LIST FOR 180SM REDUCER MOUNTING TO 601RDM

<u>ITEM NO.</u>	<u>PART NUMBER</u>	<u>DESCRIPTION</u>
1	89A39466050000	Reducer 5:1 Ratio
.....	89A39466070000	Reducer 7.5:1 Ratio
.....	89A39466100000	Reducer 10:1 Ratio
.....	89A39466150000	Reducer 15:1 Ratio
.....	89A39466200000	Reducer 20:1 Ratio
.....	89A39466250000	Reducer 25:1 Ratio
.....	89A39466300000	Reducer 30:1 Ratio
.....	89A39466400000	Reducer 40:1 Ratio
.....	89A39466500000	Reducer 50:1 Ratio
.....	89A39466600000	Reducer 60:1 Ratio
0065 RDM		
2	80C39246009100	Reducer Mounting Plate
3	95A26000420000	SHCS 1/4-20 X 1
4	95A26002030000	SHCS 1/4-20 X 3/4
5	M06K187	KEY 6MM SQ. X 1 7/8 LG
6	99A38233000000	HAND KNOB
80RDM		
2	89B67859009100	Reducer Mounting Plate
3	95A33040170000	SHCS M6 X 12
4	95A33040180001	SHCS M6 X 16
5	99A38233000000	KEY 6MM SQ. X 2.75 LG
6	99A38233000000	HAND KNOB

SPARE PARTS KITS

<u>MODEL</u>	<u>ITEM</u>	<u>PART NUMBER</u>
80RDM	Kit	SPK80RDM
601RDM	Kit	SPK601RDM
902RDM	Kit	SPK902RDM
1305RDM	Kit	SPK1305RDM
1800RDM	Kit	SPK1800RDM

Spare Parts Kit: RDM	Items Sold Separately:
<p>Bearing Cup & Cone</p> <p>Packaging</p> <p>Input O-Ring</p> <p>Output Shim</p> <p>Oil Seal</p> <p>Input Shim</p> <p>Presorted: Bolts Nuts Washers Setscrews Etc.</p>	<p>Cam Followers H16 H32 H20 H48 H24 H64</p> <p>Output Bearing</p> <p>Stationary Center Post</p> <p>Input Shaft W/Reducer & IOC</p> <p>Input Shaft W/O Reducer</p>



The Driving Force In Automation

Commercial Cam Co., Inc. (CAMCO)
1444 South Wolf Rd.
Wheeling, IL 60090 U.S.A.



Phone: (847) 459-5200 Fax: (847) 459-3064
BBS: (847) 459-1054 or (847) 459-4182
E-Mail: mktg@camcoindex.com
Internet: <http://www.camcoindex.com>



CAMCO MICHIGAN
550 Forest Avenue
Unit #14
Plymouth, MI 48170
TEL: (734) 459-8080
FAX: (734) 459-8110

CAMCO U.K.
432 Perth Avenue
Slough Trading Estate
Slough Berkshire, England
SL14TS
Tel: 44-1-753-786100
Fax: 44-1-753-786101

© Commercial Cam Co., Inc. (Camco) 1999

CAMCO • CAMBOT • CAMCARE • CAMPARTS are trademarks of Commercial Cam Co., Inc.

Printed in U.S.A.

All rights reserved

this publication is for information purposes only and should not be considered a binding description of the product except id confirmed in writing by CAMCO.