

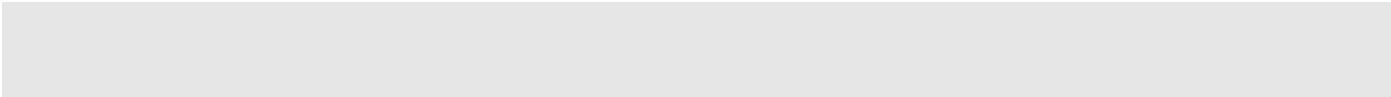

# SERVICE MANUAL

## PARALLEL SERIES INDEX DRIVES

### MODELS 250P, 387P, 512P, & 662P



**"WARNING"**

This is a controlled document. It is your responsibility to deliver this information to the end user of the CAMCO indexer.  
Failure to deliver this, could result in your liability for injury to the user or damage to the machine.  
For copies of this manual call your Customer Service Representative 800/645-5207.

## TABLE OF CONTENTS

Introduction .....	2
Warnings and Cautions .....	2
Oil Seal Removal .....	2
Spare Parts Kit Information .....	2
Disassembly .....	2,3
Removing Top Housing .....	2,3
Cam Follower Inspection and Replacement .....	3
Removing Input Shaft .....	4
Removal of Output Shaft .....	4,5
Prior to Reassembly .....	5
Installing Follower Wheel .....	5
Installing Cams .....	5,6
Installing Output Shaft .....	6
Installing Input Shaft .....	6
Setting Cam Preload .....	6,7
How to Order Parts .....	7
Exploded Parts Drawing (250P & 387P) .....	8
Parts List (250P & 387P) .....	9,10,11
Exploded Parts Drawing (512P & 662P) .....	12
Parts List (512P & 662P) .....	13,14,15

## INTRODUCTION

---

This service manual pertains to the disassembly and assembly of CAMCO's Parallel Series Index Drives models 250P, 387P, 512P, & 662P.

The manual is to be used in conjunction with the General Service Manual which describes the lubrication and general maintenance of CAMCO Index Drives.

An exploded view of your specific Index Drive is included in this manual. Also included is a complete Bill of Materials for your convenience in identifying and ordering spare or replacement parts.

Some users of Index Drives have the facilities and trained personnel to accomplish service repair. You must determine the extent to which intricate servicing should be done in your facility. When in doubt, CAMCO recommends that CAMCO trained servicemen make the repairs.

## WARNINGS AND CAUTIONS

---

Statements in this manual preceded by the words *WARNING* or *CAUTION* and printed in italics are very important. We recommend you take special notice of these during service or repair.

### *WARNING*

Means there is the possibility of personal injury to yourself or others.

### *CAUTION*

Means there is the possibility of damage to the CAMCO unit.

## OIL SEAL REMOVAL

---

The only repair possible without disassembly of the indexer is replacement of oil seals. To remove oil seals, drill a number of holes into the case of the seal. The seal may then be removed with a pointed tool. Be sure to remove all metallic chips created during the drilling of removal holes. A new seal may be installed as outlined in the "Oil Seal Installation Recommendations" section of the "General Service Manual".

## SPARE PARTS KIT

---

CAMCO offers a Spare Parts Kit for all CAMCO index drive models CAMCO builds. These kits include oil seals, bearings, shims and cam followers. These are components that will most likely require replacement during repair of your index drive. CAMCO recommends a Spare Parts Kit be purchased and kept on hand prior to any disassembly of your CAMCO drive.

A complete list of components supplied in the Spare Parts Kit can be found in the parts list located in the rear of this manual. The asterisk behind the item number indicates those parts supplied with the Spare Parts Kit.

## BEFORE STARTING

---

Before starting disassembly of your CAMCO unit you should read and review the following instructions. These provide important information on parts and procedures necessary to successfully complete your repair.

Comply with all *Warnings* and *Cautions*.

Read the "Trouble Shooting Guide" section of your "General Service Manual" before disassembling CAMCO units. CAMCO recommends returning defective equipment for inspection and repair whenever possible.

CAMCO uses Loc-tite to secure all screws and setscrews. If you encounter a fastener that is difficult to remove, apply heat to the screw and remove while still warm.

## DISASSEMBLY

---

1. Remove all accessory equipment such as clutches, reducers, sprockets, etc. If equipped with a CAMCO R200 or R250 reducer, see disassembly instructions pertaining to the appropriate reducer prior to removal from unit.
2. Drain oil and flush unit with flushing solvent. Retain any chips or broken pieces that you may find. These may aid in diagnosis.
3. REMOVING TOP HOUSING
  - A. Match mark all input cartridges relative to the housing. These must be replaced in the same side and in the same angular position, since they are eccentric.

- B. Remove the main housing screws. These hold the upper and lower housings together.
- C. Remove all bearings cartridge capscrews on the upper (smaller part) housing half.
- D. Loosen the bearing cartridge capscrews on the lower half.
- E. Remove the upper housing section. Lightly tap on the upper housing to aid in loosening and removal.
- F. Retighten bearing cartridge capscrews and rotate the input shaft with a handwheel and inspect all parts for wear or damage.

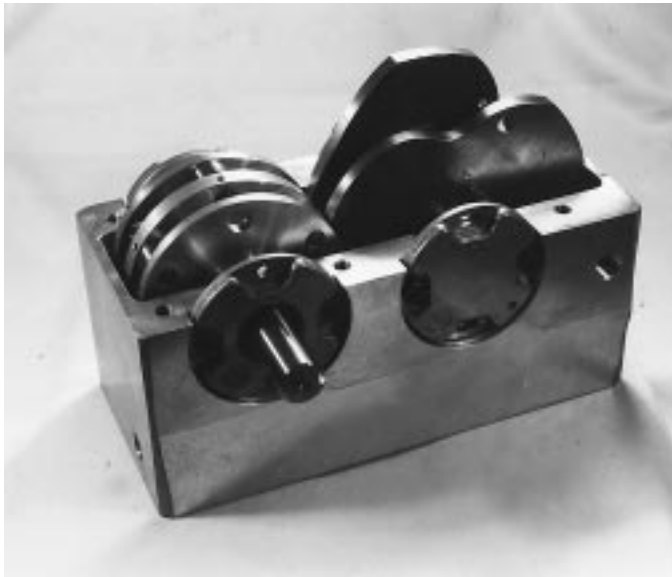

Fig.1 Top housing removed.

NOTE:

- 1) Radial follower looseness should not exceed .001.
- 2) Endplay (lack of preload) in input or output shaft is not permissible.



Fig.2 Checking radial looseness.

#### 4. CAM FOLLOWER INSPECTION AND REPLACEMENT

If necessary, the cam followers can be replaced at this stage without removing the input or output shaft but you may find it necessary to remove the shafts for ease of replacement. If so, see removal of input and output shafts. The following steps should be followed in either case.

- A. Apply heat to the setscrews holding the follower studs. They are secured with Loctite. Remove the screws while they are still warm.
- B. Gently tap follower stud toward center of indexer.

*CAUTION! Be sure that the loose needles within the follower do not fall into the unit.*

- C. Install new followers holding a complete follower assembly in place. Drive the follower stud through two flanges and follower assembly, driving out the rubber plug. Install the stud from the center of the follower wheel so that the screw notch does not score the precision follower bores. Be sure that the setscrews using the recommended Loc-tite product. (See Torque section of General Service Manual.)

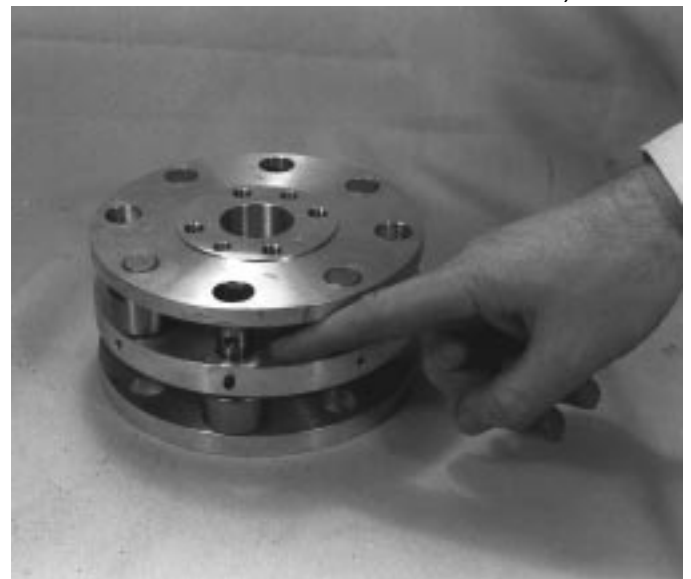

Fig.3 Installing pin from center of wheel.

#### 5. REMOVE INPUT SHAFT

- A. Remove the input bearing cartridge capscrews and gently tap the end of the input shaft until the cartridge flange is separated from the housing enough to gently pry or pull the cartridge off. If desired, tapped holes may be added to the flange portion of the cartridge for jacking screws.

- B. After removal of the cartridge, tap the shaft in the opposite direction, and remove the other cartridge in the same manner.

NOTE: You must remove the input shaft prior to removal of the output shaft.



*Fig.4 Removing input shaft.*

#### 6. REMOVAL OF OUTPUT SHAFT

- A. Removal the large output oil seal as outlined in the general statements at the front of this section.
- B. Carefully removing the snap ring, from its groove in the housing, using a snap ring pliers.



*Fig.5 Removing snap ring.*

- C. Remove the output bearing cartridge capscrews and gently tap the end of the output shaft until the cartridge flange is separated from the housing enough to pry or pull the cartridge off. If desired tapped holes may be added to the flange portion of the cartridge for jacking screws.
- D. Once the cartridge is removed, you must remove the cup portion of the output bearing that is still in the housing. This is done by using a hammer and blunt instrument (such as keystone) and gently tapping on the backside portion of the cup which extends above the housing, alternating from side to side to prevent binding, until the cup is free of the housing.
- E. Now the output shaft can be lifted free of the housing.

#### 7. For replacement of bearings:

- A. Use a wheel puller to remove the cone portion of bearing from shafts.
- B. Removal of bearing cup from cartridge: If prying is not successful it may require drilling of push off holes or fabrication of pulling device.

8. CAMCO recommends that all remaining seals be removed from the cartridges. To reuse seals is a false economy since most damage occurs during disassembly if the seal installation procedures are not followed.

9. The cam and follower wheel are slip fit on the shafts but there are several dowel pins, screws or keys holding these parts. After removing the capscrews, use an arbor press to remove cams or follower wheel from shaft using caution not to damage the parts.



Fig.6 Removing follower wheel fasteners.



Fig.7.1 Pressing out shaft.

## ASSEMBLY

### PRIOR TO REASSEMBLY

Clean and deburr all parts before reassembly.

Follow tightening torque and Loc-tite™ recommendations as outlined in the General Service Manual.

#### 1. INSTALLING FOLLOWER WHEEL

- A. Install dowels in the back side of the flange portion of the output shaft (to match up with the precision holes in the follower wheel during assembly).

- B. Use arbor to press follower wheel onto shaft. Be sure the fastener and dowel holes line up. Coat shaft and bore with anti-seize lubrication prior to pressing. If a heat gun is available it is recommended the bore of the follower wheel be heated prior to pressing.
- C. Tighten socket head capscrews.
- D. Reinstall output shaft spacers removed during disassembly.
- E. Use arbor to press bearing cones onto shaft. Coat shaft and bearing bore with anti-seize lubricant prior to pressing. If a heat gun is available it is recommended the bore of the bearing be heated prior to pressing.

#### 2. INSTALLING CAMS

- A. Use arbor to press cams onto shaft. Be sure the fastener and dowel holes or key and keyway line up. Apply anti-seize lubricant to the cam bore and shaft prior to pressing. If a heat gun is available it is recommended the bore of the cams be heated prior to pressing.

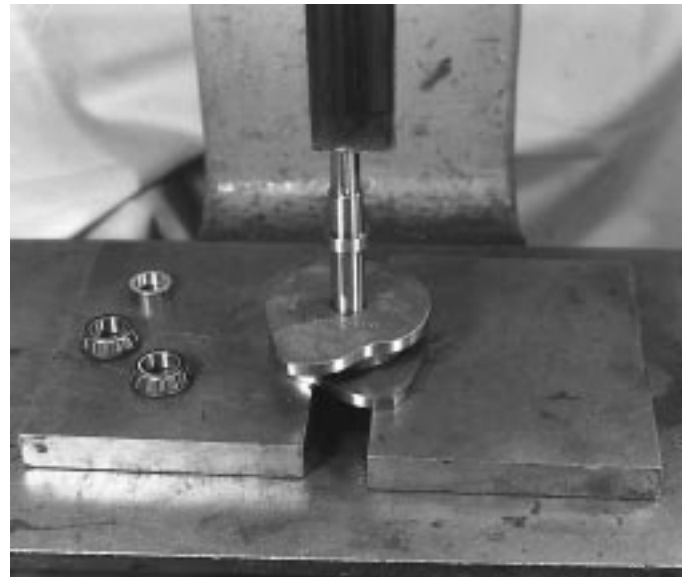

Fig.7.2 Pressing in shaft (250P)

- B. Loosely tighten cam mounting screws but do not drive in dowel pins. This note does not apply to the 250P OR 387P since they are one piece cams fastened to the shaft with keys.
- C. Reinstall input shaft spacers removed during disassembly.
- D. Use arbor to press bearing cones onto shaft. Coat shaft and bearing bore with anti-seize lubricant prior to pressing. If a heat gun is available it is recommended the bore of the bearing be heated prior to pressing.

3. Use an arbor to press the bearing cups into the cartridges. Coat the outside of the cup and the bore of the cartridge with an anti-seize lubricant prior to pressing.

#### 4. INSTALLATION OUTPUT SHAFT

- A. Place the output shaft/follower wheel assembly into the housing.
- B. Install the output cartridge into the housing and fasten with capscrews. Use the same shims as on disassembly unless endplay exists after completing steps C & D.
- C. Tap the large output bearing cup into the housing. First loosen the output cartridge and press the cup flush with the backside of the snap ring groove. Coat the outside of the cup and the housing bore with anti-seize lubricant prior to pressing.

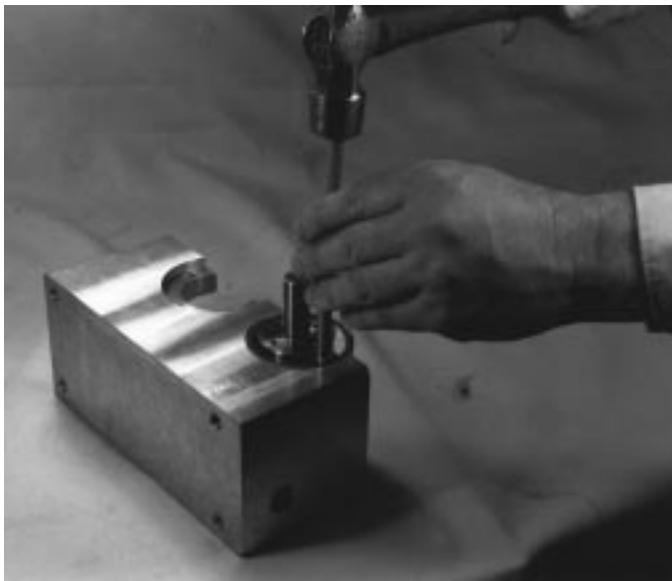

Fig.8 Installing output bearing cup

- D. Install the snap ring and tighten the output cartridge capscrews. Check the shaft for endplay. There should be a small amount of drag from preloading the bearing. If endplay exists remove shimstock from cartridge. In rare instances it may be required to remachine the cartridges if all shims have been removed and endplay still exists.

#### 5. INSTALLING INPUT SHAFT

NOTE: The output shaft must be installed prior to processing.

- A. Place the input shaft/cam assembly into the housing.
- B. Install the input shaft cartridges, aligning the match marks made during disassembly. Use the same shims as on disassembly. Loosely install the cartridge mounting capscrews.

#### 6. SETTING CAM PRELOAD

NOTE: When setting cam preload, follow steps "A" through "F".

- A. Adjust the input (eccentric) cartridges until the followers are parallel to the cam track and preload the cam slightly. Use the dwell area for this procedure (tighten cartridge capscrews).



Fig.9 Cams preloaded against followers.

*CAUTION: Improper preload results in excessive loading of the indexer. Backlash (lack of preload) is also not permissible, especially in dwell.*

- B. Apply "Prussian blue" to the entire track. Adjust the two cam plates until the Prussian blue shows a uniform pattern. Individual adjustment of the 250P and 387P does not apply since they are one piece cams.
- C. Rotate the input to each dwell position and verify that there is no looseness in dwell, If there is looseness adjust the eccentric cartridges to preload the mechanism in the loosest dwell.

- D. Repeat procedure "C".
- E. Check for smooth action by turning the input shaft. Check also the input shaft endplay as described in procedure "4D" - Installation of output shaft - adjustment shims as required.
- F. If satisfied, re-match mark the input cartridges and remove the input shaft. Drill and ream four dowel pin holes into the input shaft using the cams as a jig. (If you are still using the old input shaft or cams it will be necessary to drill and ream new holes approximately 90 degrees to the existing dowel holes in the cam. DO NOT USE THE EXISTING DOWEL HOLES. This note does not apply to the 250P or 387P.
- 7. Reinstall input shaft and apply "General Electric silicone rubber RTV-6" on all sealed surfaces, including the out cartridge.
- 8. Reinstall the upper housing section using Permatex Sealant between halves. Tighten capscrews and install dowel pins.
- 9. Drill and dowel input cartridges to the housing aligning the new match markings.
- 10. Install new oil seals as described in the General Service Manual.
- 11. Fill Index Drive with the recommended oil (see General Service Manual) to the level indicator. Too high an oil level will cause no damage. Too low a level may result in unit failure.

## HOW TO ORDER PARTS

Please refer to parts list shown in this manual. This parts list is for a standard Index Drive. If you feel your drive is nonstandard or you are in doubt you should contact CAMCO Customer Service at (847) 459-5200 and request a Bill of Material for your specific unit based on serial number. CAMCO maintains records on all units for a period of ten years.

You may order parts per the standard Bill of Material even if your unit is nonstandard. CAMCO's order entry people will review the closed file based on the following information and supply you with the correct part.

### REQUIRED INFORMATION

1. Original purchase order number (if available)
2. Customer name (original purchaser of drive)
3. Model number (located on name plate)
4. Serial number (located in name plate)
5. Approximate date of purchase.

TO ORDER PARTS contact CAMCO "Order Entry Department" Wheeling, Illinois  
Phone (847) 459-5200 or FAX #847-459-3064

A. Describe the parts required and the 14 digit part number as listed in the Standard Bill of Materials of a Special Bill of Materials pertaining to your unit. State if you are using a Standard or Special bill of material.

B. Give as much of the above required information as possible.

### ON WARRANTY

Replacement parts CAMCO will send freight prepaid via most practical means.

CAMCO will issue a "Returned Material Authorization Number" (RMA#) for the return of defective parts for inspection. CAMCO will bill customer for repair parts. When inspection of returned parts has been completed and determined to be a warranty problem, CAMCO will issue a credit to the customer for the repair parts and freight charges.

### ON NON-WARRANTY

Replacement or spare parts, with approved credit, are sent F.O.B. our plant Wheeling, Illinois.

# 250P & 387P

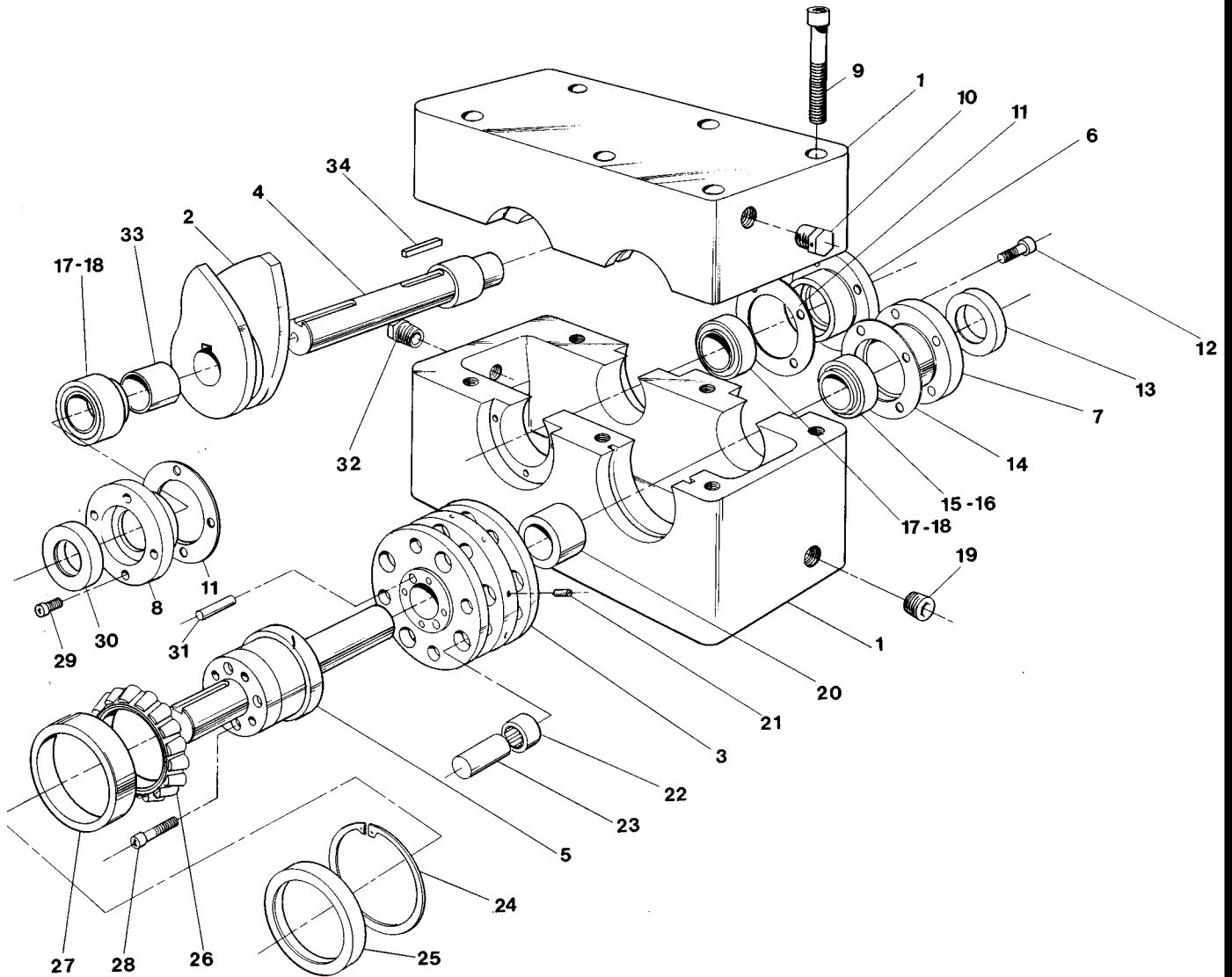

## PARTS LIST FOR 250P INDEX DRIVE (STANDARD CONFIGURATION)

<u>ITEM NO.</u>	<u>PART NUMBER</u>	<u>DESCRIPTION</u>
1 .....	24C17959011002	HOUSING 2.75 C.D. (OUTPUT HORIZONTAL EVEN W/INPUT)
.....	24C17959011002	HOUSING 2.75 C.D. (OUTPUT VERTICLE)
.....	24L17832011002	HOUSING 2.75 C.D. (OUTPUT HORIZONTAL/OVER INPUT)
.....	24J21358011002	HOUSING 2.75 C.D. (OUTPUT HORIZONTAL/UNDER INPUT)
.....	24C17959021002	HOUSING 3.25 C.D. (OUTPUT HORIZONTAL EVEN INPUT)
.....	24C17959021002	HOUSING 3.25 C.D. (OUTPUT VERTICLE)
.....	24L17832021002	HOUSING 3.25 C.D. (OUTPUT HORIZONTAL/OVER INPUT)
.....	24J21358021002	HOUSING 3.25 C.D. (OUTPUT HORIZONTAL/UNDER INPUT)
2 .....		CAM, (SPECIFY NUMBER OF STOPS AND INDEX TIME, CONTACT CAMCO FOR ASSISTANCE, ORDER IN MATCHED SETS)
3 .....	24B08867004006	FOLLOWER WHEEL 6 HOLE, 5/8" FOLLOWER
.....	24B08868004008	FOLLOWER WHEEL 8 HOLE, 5/8" FOLLOWER
.....	24K11871004002	FOLLOWER WHEEL (FOR OSCILLATORS)
4 .....	24B08897007002	INPUT SHAFT DBL EXT (W/O REDUCER)
.....	24B17627007001	INPUT SHAFT SGL EXT (W/O REDUCER)
.....	81B19913007001	INPUT SHAFT SGL EXT (FOR R200 RED.)
.....	24K12226007002	INPUT SHAFT DBL EXT (FOR R200 RED.)
5 .....	24B17628008001	OUTPUT SHAFT SGL EXT
.....	24B08865008002	OUTPUT SHAFT DBL EXT
6 .....	24B17670003112	CARTRIDGE CLOSED ECC
7 .....	24B17669003111	CARTRIDGE CLOSED OUTPUT
.....	24B17668003512	CARTRIDGE OPEN OUTPUT
8 .....	24B17958003122	CARTRIDGE OPEN ECC
9 .....	95A26000480000	SHCS 1/4-20 X 2 1/2
10 .....	95A33000010000	AIR VENT (BREATHER)
11* .....	24A17961018800	SHIM, .002 THK
* .....	24A17961028800	SHIM, .005 THK
* .....	24A17961038800	SHIM, .010 THK
12 .....	95A26003210000	SHCS 10-32 X 3/8
13* .....	84D07329050000	OIL SEAL C/R 6204
14* .....	24A17674018800	SHIM, .002 THK
* .....	24A17674018800	SHIM, .005 THK
* .....	24A17674018800	SHIM, .010 THK
15* .....	86D7328060022	BEARING CUP A5144
16* .....	86D07328060021	BEARING CONE A5069
17* .....	86D07328070022	BEARING CUP A6157
18* .....	86D07328070021	BEARING CONE A6075
19 .....	95A33003010000	MAGNETIC PLUG
20 .....		NOT USED ON 250P
21 .....	95A26005100000	SSS CUP PT 6-40 X 3/16
22 .....	82B08417010002	CAM FOLLOWER 5/8 DIA.
.....	82J13456000002	CAM FOLLOWER 3/4 DIA.

## PARTS LIST FOR 250P CONTINUED

23 .....	24A032286009800	STUD FOR 5/8 DIA. FOLLOWER
.....	24J11902009800	STUD FOR 3/4 DIA. FOLLOWER
24 .....	95A33029520000	RETAINING RING N5000-250
25* .....	84D07329300000	OIL SEAL C/R 17386
26* .....	86D07328310021	BEARING CONE 13889
27* .....	86D07328310022	BEARING CUP 13830
28 .....	95A26000240000	SHCS 8-32 X 1
29 .....	95A26003210000	BHCS 10-32 X 3/8
30* .....	84D07329080000	OIL SEAL C/R 7443
31 .....	95A26007120000	DOWELL PIN 3/16 X 1/2
32 .....	95A33001010000	SIGHT GLASS
33 .....	24A08898009000	SPACER, INPUT
34 .....	018K106	KEY 3/16 SQ. X 1 1/16 LG

\*Indicates parts supplied with Spare Parts Kit #250P SPK

## PARTS LIST FOR 387P INDEX DRIVE (STANDARD CONFIGURATION)

<u>ITEM NO.</u>	<u>PART NUMBER</u>	<u>DESCRIPTION</u>
1 .....	26D08838011002	HOUSING 4.00 C.D.
.....	.....	(OUTPUT HORIZONTAL EVEN W/INPUT)
.....	26D08838011002	HOUSING 4.00 C.D.
.....	.....	(OUTPUT VERTICLE)
.....	26L11921011002	HOUSING 4.00 C.D.
.....	.....	(OUTPUT HORIZONTAL/OVER INPUT)
.....	26L18075011002	HOUSING 4.00 C.D.
.....	.....	(OUTPUT HORIZONTAL/UNDER INPUT)
.....	26D08838021002	HOUSING 4.81 C.D.
.....	.....	(OUTPUT HORIZONTAL EVEN INPUT)
.....	26D08838021002	HOUSING 4.81 C.D.
.....	.....	(OUTPUT VERTICLE)
.....	26L11921021002	HOUSING 4.81 C.D.
.....	.....	(OUTPUT HORIZONTAL/OVER INPUT)
.....	26L18075021002	HOUSING 4.81 C.D.
.....	.....	(OUTPUT HORIZONTAL/UNDER INPUT)
2 .....	-----	CAM, (SPECIFY NUMBER OF STOPS AND INDEX TIME, CONTACT CAMCO FOR ASSISTANCE, ORDER IN MATCHED SETS)
3 .....	26B08760004006	FOLLOWER WHEEL 6 HOLE, 7/8" FOLLOWER
.....	26B09095004008	FOLLOWER WHEEL 8 HOLE, 7/8" FOLLOWER
.....	26K12231004002	FOLLOWER WHEEL (FOR OSCILLATORS)
.....	26K24047004006	FOLLOWER WHEEL 6 HOLE, 1" FOLLOWER
.....	26K24047004006	FOLLOWER WHEEL 8 HOLE, 1" FOLLOWER
4 .....	26B03212007002	INPUT SHAFT SGL EXT (W/O REDUCER)
.....	26B03213007001	INPUT SHAFT DBL EXT (W/O REDUCER)
.....	83B07530007001	INPUT SHAFT SGL EXT (FOR R250 RED.)
.....	83K07865007002	INPUT SHAFT DBL EXT (FOR R250 RED.)
5 .....	26B08839008001	OUTPUT SHAFT SGL EXT
.....	26B08920008002	OUTPUT SHAFT DBL EXT
6 .....	26B01054003112	CARTRIDGE CLOSED ECC

## PARTS LIST FOR 387P CONTINUED

7 .....	26B01553003112	CARTRIDGE CLOSED OUTPUT
.....	26B01552003121	CARTRIDGE OPEN OUTPUT
8 .....	26B01048003122	CARTRIDGE OPEN ECC
9 .....	95A26000820000	SHCS 3/8-16 X 4
10 .....	95A33000010000	AIR VENT (BREATHING)
11* .....	26B01052018800	SHIM, .002 THK
* .....	26B01052028800	SHIM, .005 THK
* .....	26B01052038800	SHIM, .010 THK
12 .....	95A26000390000	SHCS 1/4-20 X 5/8
13* .....	84D07329130000	OIL SEAL C/R 9838
14* .....	26B01052018800	SHIM, .002 THK
* .....	26B01052028800	SHIM, .005 THK
* .....	26B01052038800	SHIM, .010 THK
15* .....	86D07328170022	BEARING CUP 07196
16* .....	86D07328170021	BEARING CONE 07100
17* .....	86D07328170022	BEARING CUP 07196
18* .....	86D07328170021	BEARING CONE 07100
19 .....	95A33003010000	MAGNETIC PLUG
20 .....	26B01051049000	SPACER, OUTPUT
21 .....	95A26005380000	SSS CUP PT 10-32 X 5/16
22 .....	82B08417020002	CAM FOLLOWER 7/8 DIA.
.....	82B08417070002	CAM FOLLOWER 1 DIA.
23 .....	26A03288009800	STUD FOR 7/8 DIA. FOLLOWER
.....	26J10593009800	STUD FOR 1 DIA. FOLLOWER
24 .....	95A33029760000	RETAINING RING N5000-375
25* .....	84D07329460000	OIL SEAL C/R 25091
26* .....	86D07328530021	BEARING CONE L610549
27* .....	86D07328530022	BEARING CUP L610510
28 .....	95A26016260000	SHCS 1/4-28 X 1 1/2
29 .....	95A08089000000	SPECIAL LARGE HEAD CAPSCREW
30* .....	84D07329130000	OIL SEAL C/R 9838
31 .....	95A26007330000	DOWEL PIN 5/16 X 5/8
32 .....	95A33001010000	SIGHT GLASS
33 .....	26B01051019000	SPACER, INPUT
34 .....	025K131	KEY 1/4 SQ X 1 5/16 LG

\*Indicates parts supplied with Spare Parts Kit #387P SPK

# 512P & 662P

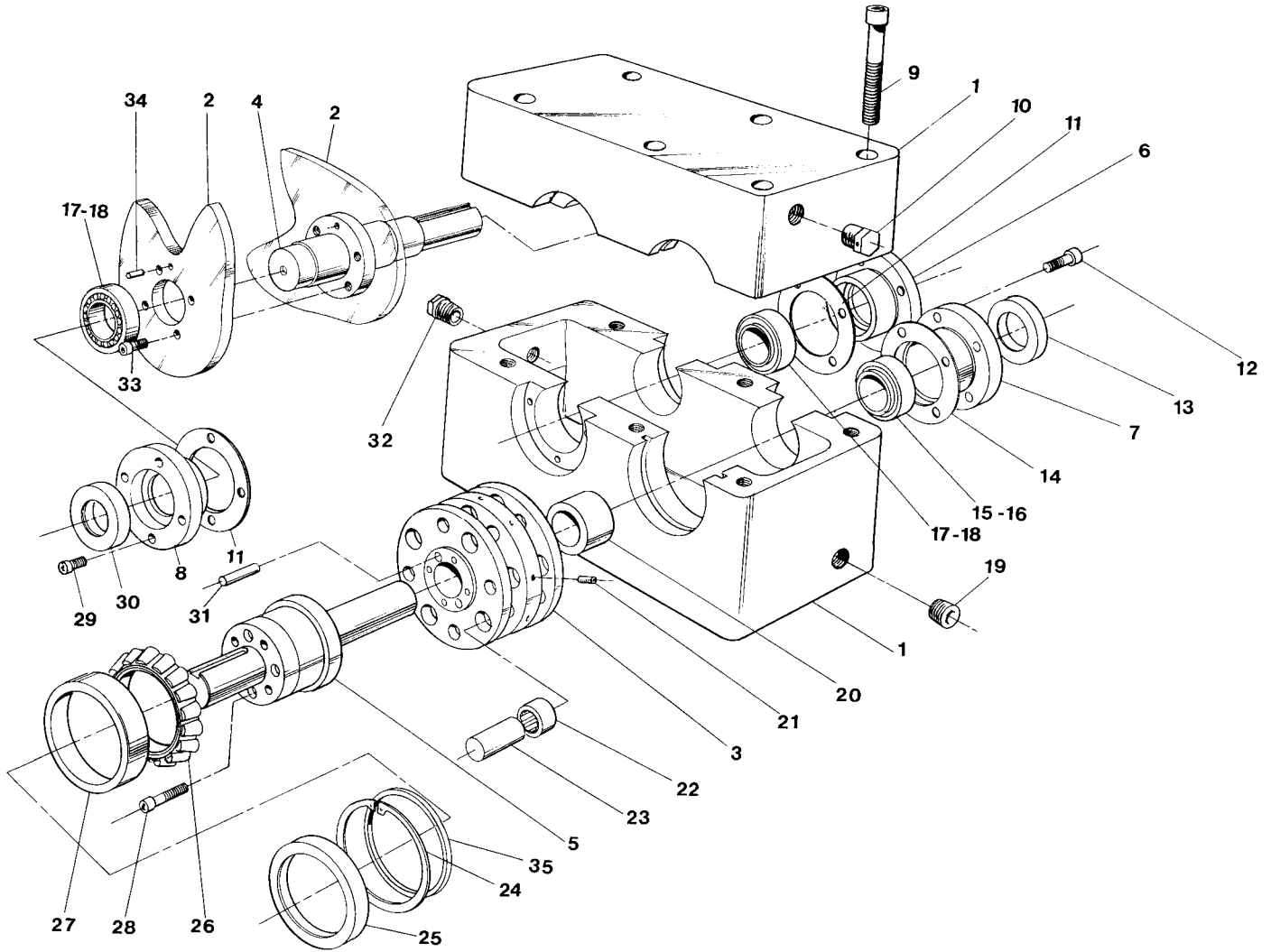

## PARTS LIST FOR 512P INDEX DRIVE (STANDARD CONFIGURATION)

<u>ITEM NO.</u>	<u>PART NUMBER</u>	<u>DESCRIPTION</u>
1 .....	28D0896011002	HOUSING 4.85 C.D. (OUTPUT HORIZONTAL EVEN W/INPUT)
.....	28D0896011002	HOUSING 4.85 C.D. (OUTPUT VERTICLE)
.....	28L13176011002	HOUSING 4.85 C.D. (OUTPUT HORIZONTAL/OVER INPUT)
.....	28L21114011002	HOUSING 4.85 C.D. (OUTPUT HORIZONTAL/UNDER INPUT)
.....	28D08969021002	HOUSING 5.98 C.D. (OUTPUT HORIZONTAL EVEN INPUT)
.....	28D08969021002	HOUSING 5.98 C.D. (OUTPUT VERTICLE)
.....	28L13176021002	HOUSING 5.98 C.D. (OUTPUT HORIZONTAL/OVER INPUT)
.....	28L21114021002	HOUSING 5.98 C.D. (OUTPUT HORIZONTAL/UNDER INPUT)
2 .....		CAM, (SPECIFY NUMBER OF STOPS AND INDEX TIME, CONTACT CAMCO FOR ASSISTANCE, ORDER IN MATCHED SETS)
3 .....	28B08970004006	FOLLOWER WHEEL 6 HOLE, 1 1/4 FOLLOWER
.....	28B08971004008	FOLLOWER WHEEL 8 HOLE, 1 1/4 FOLLOWER
.....	28K18742004008	FOLLOWER WHEEL 6 HOLE, 1 1/2 FOLLOWER
.....	28K15308004008	FOLLOWER WHEEL 8 HOLE, 1 1/2 FOLLOWER
.....	28K13108004002	FOLLOWER WHEEL (FOR OSCILATORS)
4 .....	28C03222007002	INPUT SHAFT DBL EXT (W/O REDUCER)
.....	28C03221007001	INPUT SHAFT SGL EXT (W/O REDUCER)
.....	83C05414007001	INPUT SHAFT SGL EXT (FOR R250 RED.)
.....	80C02941007001	INPUT SHAFT SGL EXT (FOR 3" RED.)
.....	80C02941007001	INPUT SHAFT SGL EXT (FOR 3 1/2" RED.)
.....	80L03545007002	INPUT SHAFT DBL EXT (FOR 3" RED.)
.....	80L03545007002	INPUT SHAFT DBL EXT (FOR 3 1/2" RED.)
5 .....	28C08972008001	OUTPUT SHAFT SGL EXT
.....	28C08973008002	OUTPUT SHAFT DBL EXT
6 .....	28K26354003012	CARTRIDGE CLOSED ECC
7 .....	28K26352003011	CARTRIDGE CLOSED OUTPUT
.....	28K26353003011	CARTRIDGE OPEN OUTPUT
8 .....	28K26355003022	CARTRIDGE OPEN ECC
9 .....	95A26000840000	SHCS 3/8-16 X 5
10 .....	95A33000010000	AIR VENT (BREATHNER)
11* .....	28A02522018800	SHIM, .002 THK
* .....	28A02522028800	SHIM, .005 THK
* .....	28A02522028800	SHIM, .010 THK
12 .....	95A26000390000	SHCS 1/4-20 X 5/8
13* .....	84D07329220000	OIL SEAL C/R 450463
14* .....	28A02522018800	SHIM, .002 THK
* .....	28A02522028800	SHIM, .005 THK
* .....	28A02522038800	SHIM, .010 THK
15* .....	86D07328280022	BEARING CUP 26822
16* .....	86D07328280021	BEARING CONE 26883
17* .....	86D07328280022	BEARING CUP 26822
18* .....	86D07328440021	BEARING CONE 26885

## PARTS LIST FOR 512P CONTINUED

19 .....	95A33003010000	MAGNETIC PLUG
20 .....	28B02533019000	SPACER, OUTPUT
21 .....	95A26005390000	SSS CUP PT 10-32 X 3/8
22 .....	82B08417030002	CAM FOLLOWER 1 1/4 DIA.
.....	82J09674000002	CAM FOLLOWER 1 1/2 DIA.
23 .....	28A03342009800	STUD FOR 1 1/4 DIA. FOLLOWER
.....	28J09345009800	STUD FOR 1 1/2 DIA. FOLLOWER
24 .....	95A33029840000	RETAINING RING N5000-462
25* .....	84D07329590000	OILSEAL C/R 32540
26* .....	86D07328680021	BEARING CONE L116149
27* .....	86D07328680022	BEARING CUP L116110
28 .....	95A26016480000	SHCS 3/8-24 X 1 1/4
29 .....	95A08089000000	SPECIAL LARGE HEAD CAPSCREW
30* .....	84D07329290000	OIL SEAL C/R 16368
31 .....	95A26007530000	DOWEL PIN 7/16 X 1
32 .....	95A33001010000	SIGHT GLASS
33 .....	95A26017330000	HHCS 3/8-24 X 2
34 .....	95A26007340000	DOWEL PIN 5/16 X 3/4
35 .....	28A09012009000	SPACER OUTPUT

\*Indicates parts supplied with Spare Parts Kit #512P SPK

## PARTS LIST FOR 662P INDEX DRIVE (STANDARD CONFIGURATION)

<u>ITEM NO.</u>	<u>PART NUMBER</u>	<u>DESCRIPTION</u>
1 .....	30D09026011004	HOUSING 6.28 C.D.
.....	.....	(OUTPUT HORIZONTAL EVEN W/INPUT)
.....	30D09026011004	HOUSING 6.28 C.D.
.....	.....	(OUTPUT VERTICLE)
.....	30L15313011004	HOUSING 6.28 C.D.
.....	.....	(OUTPUT HORIZONTAL/OVER INPUT)
.....	30C36019011004	HOUSING 6.28 C.D.
.....	.....	(OUTPUT HORIZONTAL/UNDER INPUT)
.....	30D09026021004	HOUSING 7.73 C.D.
.....	.....	(OUTPUT HORIZONTAL EVEN INPUT)
.....	30D09026021004	HOUSING 7.73 C.D.
.....	.....	(OUTPUT VERTICLE)
.....	30L15313021004	HOUSING 7.73 C.D.
.....	.....	(OUTPUT HORIZONTAL/OVER INPUT)
.....	30C36019021004	HOUSING 7.73 C.D.
.....	.....	(OUTPUT HORIZONTAL/UNDER INPUT)
2 .....	.....	CAM, (SPECIFY NUMBER OF STOPS AND INDEX
.....	.....	TIME, CONTACT CAMCO FOR ASSISTANCE,
.....	.....	ORDER IN MATCHED SETS)
3 .....	30C09027004006	FOLLOWER WHEEL 6 HOLE, 1 1/2 FOLLOWER
.....	30C09107004008	FOLLOWER WHEEL 8 HOLE, 1 1/2 FOLLOWER
.....	30L17891004006	FOLLOWER WHEEL 6 HOLE, 1 3/4 FOLLOWER
.....	30L16226004008	FOLLOWER WHEEL 8 HOLE, 1 3/4 FOLLOWER
.....	30L12966004002	FOLLOWER WHEEL (FOR OSCILATORS)
4 .....	30B02653007001	INPUT SHAFT SGL EXT (W/O REDUCER)

## PARTS LIST FOR 662P CONTINUED

.....	30B02649007002	INPUT SHAFT DBL EXT (W/O REDUCER)
.....	80B03518007001	INPUT SHAFT SGL EXT (FOR 3" RED.)
.....	80B03518007001	INPUT SHAFT SGL EXT (FOR 3 1/2" RED.)
.....	80B03518007001	INPUT SHAFT SGL EXT (FOR 4" RED.)
.....	80K08000007002	INPUT SHAFT DBL EXT (FOR 3" RED.)
.....	80K08000007002	INPUT SHAFT DBL EXT (FOR 3" RED.)
.....	80K08000007002	INPUT SHAFT DBL EXT (FOR 3 1/2" RED.)
.....	80K08000007002	INPUT SHAFT DBL EXT (FOR 4" RED.)
5 .....	30C09029008002	OUTPUT SHAFT DBL EXT
.....	30C09028008001	OUTPUT SHAFT SGL EXT
6 .....	30B07731003012	CARTRIDGE CLOSED ECC
7 .....	30B07729003011	CARTRIDGE CLOSED OUTPUT
.....	30B07728003021	CARTRIDGE OPEN OUTPUT
8 .....	30B07730003112	CARTRIDGE OPEN ECC
9 .....	95A26001200000	SHCS 1/2-13 X 6
10 .....	95A33000010000	AIR VENT (BREATHING)
11* .....	30B02669018800	SHIM, .002 THK
* .....	30B02669028800	SHIM, .005 THK
* .....	30B02669038800	SHIM, .010 THK
12 .....	95A26000690000	SHCS 3/8-16 X 3/4
13* .....	84D07329270000	OIL SEAL C/R 15215
14* .....	30B02669018800	SHIM, .002 THK
* .....	30B02669028800	SHIM, .005 THK
* .....	30B02669038800	SHIM, .010 THK
15* .....	86D07328340022	BEARING CUP 3720
16* .....	86D07328340021	BEARING CONE 3774
17* .....	86D07328340022	BEARING CUP 3720
18* .....	86D07328440021	BEARING CONE 3767
19 .....	95A33003010000	MAGNETIC PLUG
20 .....	30A02656009000	SPACER, OUTPUT
21 .....	95A26005530000	SSS CUP PT 1/4-28 X 3/8
22 .....	82J10188000002	CAM FOLLOWER 1 3/4 DIA.
.....	82B08417040002	CAM FOLLOWER 1 1/2 DIA.
23 .....	30J10240009800	STUD FOR 1 3/4 DIA. FOLLOWER
.....	30A02650009800	STUD FOR 1 1/2 DIA. FOLLOWER
24 .....	95A33029910000	RETAINING RING N5000-575
25* .....	84D07329670000	OIL SEAL C/R 42573
26* .....	86D07328750021	BEARING CONE L521949
27* .....	86D07328670022	BEARING CUP L521910
28 .....	95A26016600000	SHCS 7/16-20 X 2
29 .....	95A08116999999	SPECIAL LARGE HEAD CAPSCREW
30* .....	84D07329350000	OIL SEAL NAT 450389
31 .....	95A26007630000	DOWEL PIN 1/2 X 1 1/4
32 .....	95A33001010000	SIGHT GLASS
33 .....	95A26017440000	HHCS 1/2-20 X 1/4
34 .....	95A26007620000	DOWEL PIN 1/2 X 1
35 .....	30A09030009000	SPACER OUTPUT

\* Indicates parts supplied with Spare Parts Kit #622P SPK

# NOTES



The Driving Force In Automation

Commercial Cam Co., Inc. (CAMCO)  
1444 South Wolf Rd.  
Wheeling, IL 60090 U.S.A.



Phone: (847) 459-5200 Fax: (847) 459-3064  
BBS: (847) 459-1054 or (847) 459-4182  
E-Mail: [mktg@camcoindex.com](mailto:mktg@camcoindex.com)  
Internet: <http://www.camcoindex.com>



CAMCO MICHIGAN  
550 Forest Avenue  
Unit #14  
Plymouth, MI 48170  
TEL: (734) 459-8080  
FAX: (734) 459-8110

CAMCO U.K.  
432 Perth Avenue  
Slough Trading Estate  
Slough Berkshire, England  
SL14TS  
Tel: 44-1-753-786100  
Fax: 44-1-753-786101

© Commercial Cam Co., Inc. (Camco) 1999

CAMCO • CAMBOT • CAMCARE • CAMPARTS are trademarks of Commercial Cam Co., Inc.  
this publication is for information purposes only and should not be considered a binding description of the product except id confirmed in writing by CAMCO.

Printed in U.S.A.

All rights reserved

USA 6/99 0068