



A DOVER COMPANY

Automation
Robohand FERGUSON
CAMCO

SERVICE MANUAL

CAMCO RITE-LINK CONVEYORS 75mm, 115mm and 150mm LINKS

WARNING

This is a controlled document. It is your responsibility to deliver this information to the end user of the CAMCO or FERGUSON product. Failure to deliver this could result in your liability for injury to the user or damage to the machine. For copies of this manual, call your Customer Service Representative at 800-645-5207 or 847-459-5200 or download the pdf from www.destaco.com.

TABLE OF CONTENTS

INTRODUCTION	2
GENERAL DESCRIPTION	2
WARNINGS AND CAUTIONS	2
SPARE PARTS	3
BEFORE STARTING	3
CONVEYOR LUBRICATION INFORMATION	4
GENERAL.....	4
LUBRICATION OF SPROCKET BEARINGS.....	4
GENERAL MAINTENANCE LUBRICATION.....	4
CHANGING OF ROLLERS AND BUSHINGS.....	4
CHANGING PLASTIC BUSHINGS.....	4
CHANGING ROLLERS.....	4
CHANGING LINK PIN BEARINGS.....	4
CHANGING LINK SUPPORT BEARINGS	4-5
CONVEYOR TENSION SETTING.....	6
GENERAL INFORMATION	6
CONVEYOR RE-TENSIONING.....	6
HOW TO ORDER PARTS.....	7
REQUIRED INFORMATION	7
WARRANTY	7
NON-WARRANTY	7
LINK ASSEMBLY & PARTS LIST	8-16

INTRODUCTION

This service manual pertains to the disassembly and assembly of the CAMCO Rite-Link conveyor (75mm, 115mm and 150mm links)

The CAMCO Rite-Link conveyor comes in two types: "over and under" and "carousel." Both can be driven by a CAMCO index drive containing cam followers and a precision cam. Inspection and service on the index drives is covered in a separate Service Manual for the specific model index drive.

This manual is to be used in conjunction with the General Service Manual, which describes the lubrication and general maintenance of CAMCO index drives.

Drawings of the various size links are included in this manual. The procedures in this manual reference the item numbers of these drawings.

Also included is a complete Bill of Materials for your convenience in identifying and ordering spare or replacement parts.

Some users of CAMCO Rite-Link conveyors have the facilities and trained personnel to accomplish service repair. You must determine the extent to which intricate servicing should be done in your facility. When in doubt, DE-STA-CO recommends that a trained CAMCO serviceman make the repairs.

GENERAL DESCRIPTION

The CAMCO Rite-Link conveyor is a precision mechanical device that requires no internal adjustment during its expected service life when operated within rated loads and speeds.

CAMCO Rite-Link conveyors employ the "link on link" design, meaning all links are identical to one another and every link can be used for fixture mounting, rather than the "link on spacer bar" design which only allows every other link to be used for fixture mounting.

NOTE: Numbers in the parts description refer to the Link Assembly Drawing and Parts List shown on pages 8-16.

The connection of the two links consists of a precision ground link pin with precision plastic bushings in each link ear.

The ends of each link are fitted with precision pins on which are placed ball bearings that are separated from the link by a washer and constrained by a retaining ring. These support the loads on the face of the link, as well as restrict face in-and-out movement.

Each link is furnished with link support ball bearings to support loads and eliminate any movement between the link and conveyor main frame.

WARNINGS AND CAUTIONS

Statements in this manual preceded by the words **WARNING** or **CAUTION** and printed in italics are very important. We recommend you take special notice of these during service or repair.

WARNING

Means there is the possibility of personal injury to yourself or others.

CAUTION

Means there is the possibility of damage to the CAMCO unit.

SPARE PARTS

Individual components may be purchased in any quantity by specifying the serial number of the conveyor – located on the saddle plate within the sprocket guard – and referencing the parts as listed in this service manual.

NOTE: The part numbers for your specific conveyor may vary from the part numbers in this manual. Always provide the serial number of your conveyor when ordering parts so we may provide the correct parts for your equipment.

BEFORE STARTING

Before starting disassembly of your CAMCO unit you should read and review the following instructions. These provide important information on parts and procedures necessary to successfully complete your repair.

Comply with all *Warnings and Cautions*.

Read the “Trouble Shooting Guide” section of your General Service Manual before disassembling CAMCO units. DE-STA-CO recommends returning defective equipment for inspection and repair whenever possible.

DE-STA-CO uses Loctite™ adhesive to secure all screws and set screws. If you encounter a fastener that is difficult to remove, apply heat to the screw and remove while still warm.

CONVEYOR LUBRICATION INFORMATION

GENERAL

CAMCO Rite-Link conveyors require little maintenance. The links are “lube for life.” Other components should be lubricated as described below.

LUBRICATION OF SPROCKET BEARINGS

The flange bearings supporting the sprocket/input shaft should be lubricated with NGLI #3 bearing grease approximately every 2,000 working hours.

GENERAL MAINTENANCE LUBRICATION

The general condition of all unpainted components should be observed periodically and given a light spray of machine oil, as required, to retard rust.

CHANGING OF ROLLERS AND BUSHINGS

NOTE: Numbers in these instructions refer to the Rite-Link assembly drawing and parts list on pages 8-16.

CHANGING PLASTIC BUSHINGS

If the plastic bushings of the CAMCO Rite-Link conveyor need to be replaced, the entire link must be removed. Bushings can be pushed up using an arbor press and then removed.

CHANGING ROLLERS

The changing of the rollers on CAMCO Rite-Link conveyors is done by two methods, depending upon which bearing is worn.

The procedure for changing the link pin bearings is different from the procedure for the link support bearings. The following sections describe the steps required for each procedure.

CHANGING LINK PIN BEARINGS

1. Remove the UHMW plastic guards to access the link with the worn bearing.
 2. Remove the guards from the drive end of the conveyor.
 3. Index the conveyor until the worn link pin bearings are exposed at the end of the conveyor.
 4. Back off the tensioning screws two turns. Refer to Figure 1 and Figure 3.
 5. Remove the retaining ring holding the bearing on pin.
 6. Remove the worn or damaged bearing and replace.
- CAUTION: Thrust washers are used between the link and bearing, so be sure to replace the washer before installing the new bearing.
7. Repeat until all worn or damaged bearings are replaced.

CHANGING LINK SUPPORT BEARINGS

1. Remove the UHMW plastic guards to access the link with the worn bearing.
2. Remove the guards from the drive end of the conveyor.
3. Index the conveyor until the worn link pin bearings are exposed at the end of the conveyor.
4. Back off the tensioning screws two turns. Refer to Figure 1 and Figure 3.

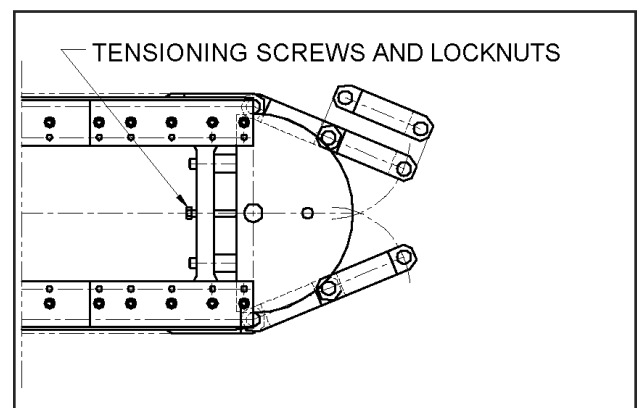

Figure 1 Removing link

5. Remove retaining rings on the link pins of the link to be removed.

WARNING: Use caution when pulling chain for section removal. The chain should be held back so that a runaway condition does not occur. This can happen when the weight of the chain outside the conveyor overcomes the friction of the chain still inside the conveyor, causing all the links to feed out uncontrollably.

6. Remove bearings and thrust washers from one side only. Retain thrust washers for reassembly.
7. Pull pins with remaining bearings through all four ears of the link connection.
8. Once the link has been removed, place the link on a work bench and remove the bearing locknut.
9. Using a soft aluminum bar, drive out the worn bearing.
10. Press in a new bearing and install a new locknut.
11. Place the link back into position so that alignment of the link ears will permit insertion of the link pin.
12. Insert pins through all four ears of the link connection.
13. Reinstall bearings and thrust washers.

14. Tighten the tensioning screws.

15. Reinstall retaining rings on the link pins.

16. If other links are to be removed, it will be necessary to hand crank the drive (due to the lack of chain tension) until the link to be removed is exposed at the take-up end. Repeat Steps 5 through 15 as many times as required to replace all worn followers.

WARNING: Use caution when pulling chain for section removal. The chain should be held back so that a runaway condition does not occur. This can happen when the weight of the chain outside the conveyor overcomes the friction of the chain still inside the conveyor, causing all the links to feed out uncontrollably.

NOTE: When rebuilding all links, the chain can be removed in large sections by breaking the chain at the drive end as well as at the take-up end. Pull a manageable length of chain out from take-up end. It is recommended that links be reassembled in the same order as received from DE-STA-CO. Number links before disassembly.

17. When all followers are changed, re-tension the chain as described in the "Conveyor Tension Setting" section of this manual.

CONVEYOR TENSION SETTING

GENERAL INFORMATION

To maintain and guarantee accuracy and performance of the conveyor, DE-STA-CO uses a state-of-the-art, chordal action compensating conveyor design. DE-STA-CO rejected spring-actuated tensioned conveyors that use either tail shaft or secondary tensioning because these old designs contribute to indexing inaccuracies.

Once the Rite-Link conveyor is properly tensioned at the factory, no further adjustment is required in the field for the duration of expected bearing life. We are including instructions for adjustments, should it become necessary to replace bearings, or if the tension is lost because of extraordinary conditions (e.g., extreme thermal expansion). It is recommended that the DE-STA-CO factory be consulted prior to starting with the actual adjustment. Failure to do so may void all warranties for the conveyor.

CONVEYOR RE-TENSIONING

1. Read the section in general information regarding warranty.
2. Remove the UHMW plastic guards.
3. Remove the radial guides at the take-up end of the conveyor.

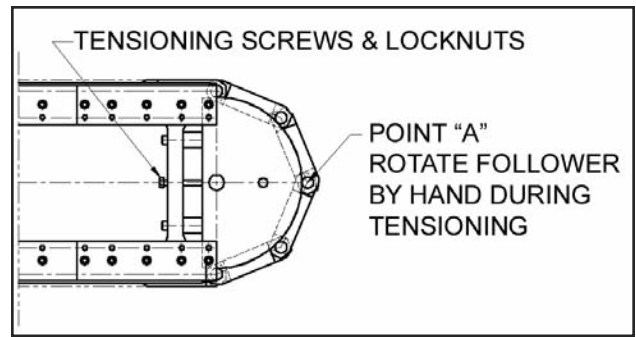

Figure 2 Conveyor re-tensioning

4. Hand crank the index drive input reducer until a link pin bearing is positioned at the high point of the take-up cam (point "A" as shown in Figure 2).

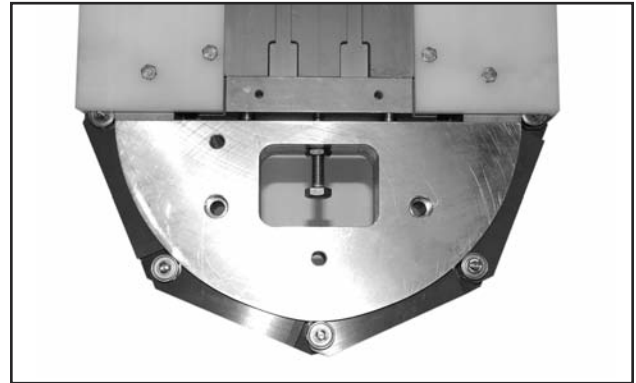

Figure 3

5. Slowly tighten the tensioning screw until it becomes impossible to turn the link pin bearing, at point "A", by hand. It should still be easy to turn the bearing using pliers. If it is difficult with pliers, you have overtightened.
6. Tighten jamb nut.
7. Re-install the radial guides and UHMW plastic guards.

HOW TO ORDER PARTS

Please refer to the parts list shown in this manual. This parts list is for a standard Rite-Link conveyor. If you feel your unit is nonstandard, or you are in doubt, contact DE-STA-CO's CAMCO products customer service at (847) 459-5200 and request a Bill of Material for your specific unit based on serial number. DE-STA-CO maintains records on all units for a period of 10 years.

You may order parts per the Standard Bill of Material even if your unit is nonstandard. CAMCO's customer service representatives will review the closed order file based on the following information and supply you with the correct part.

REQUIRED INFORMATION

1. Original purchase order number (if available)
2. Customer name (original purchaser of conveyor)
3. Model number (located on name plate)
4. Serial number (located on saddle plate within the sprocket guard)
5. Approximate date of purchase

Contact CAMCO's Order Entry Department in Wheeling, Illinois:

- Phone (847) 459-5200
- FAX (847) 459-3064

1. Describe the parts required and provide the 14-digit part number listed in the Standard Bill of Material or the Special Bill of Material pertaining to your unit. Tell your customer service representative if you are using the Standard or Special Bill of Material.
2. Provide as much the above required information as possible.

WARRANTY / NON-WARRANTY INFORMATION

WARRANTY

DE-STA-CO will send replacement parts, freight prepaid, via practical means.

DE-STA-CO will issue a returned material authorization (RMA) number for the return of defective parts for inspection. DE-STA-CO will bill the customer for repair parts. When inspection of the returned parts has been completed and determined to be a warranty problem, DE-STA-CO will issue a credit to the customer for the repair parts and freight charges.

NON-WARRANTY

Replacement or spare parts, with approved credit, are sent F.O.B. from our plant in Wheeling, Illinois.

75MM CAMCO RITE-LINK CONVEYOR

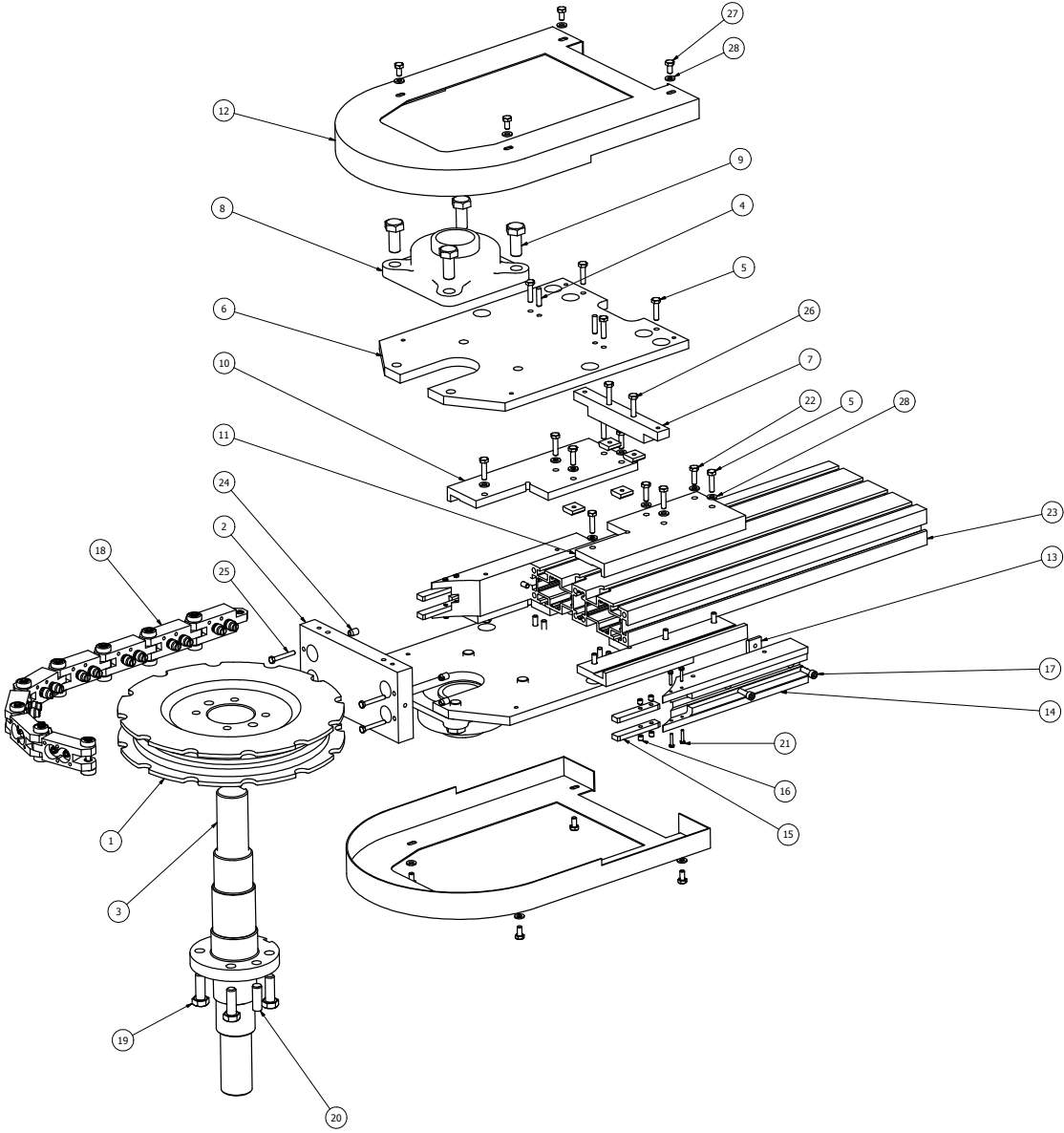

INDUSTRIAL 75MM PARTS LIST

<u>ITEM</u>	<u>QTY</u>	<u>PART NUMBER</u>	<u>DESCRIPTION</u>
1	1	1LD93479000000	SPROCKET, IND RITE-LINK
2	1	2LC92391000000	PLATE, IND DRIVE END
3	1	2LD92397007002	SHAFT INPUT DE, RITE-LINK 40/40MM DIA
4	4	95A92166030000	PULL DOWEL PIN SS 6MM X 25L
5	20	95A92169260000	MHHCS SS M6 X 25L
6	1	1LD93729000000	SIDE PLATE SET, IND RITE-LINK
7	2	1LB93352000000	SPACER, IND RITE-LINK
8	2	86A92426000000	FLANGE BEARING, IND RITE-LINK
9	8	95B63342040000	MHHCS SS M14-2 X 35L
10	2	1LC93354000000	SIDE PLATE, LH DRIVE END
11	2	1LC93355000000	SIDE PLATE, RH DRIVE END
12	2	1LD93374000000	GUARD - SS, DRIVE END RITE LINK
13	14	95A92137010000	T-SLOT NUT - SS, M6
14	2	1LD93115000000	GUIDE BAR, RITE-LINK DRIVE SIDE
15	4	2LA92939000000	LINK SUPPORT, RITE-LINK
16	8	95A67856100000	THREADED INSERT, SS M3 X 6.5L
17	4	95A92170190000	MSHCS SS M6 X 20L
18	(VARIES)	1L SLINK-IND	LINK ASSEMBLY 75MM IND RITE-LINK
19	4	95A92169700000	MHHCS SS M12 X 35L
20	1	95A92743980000	DOWEL PIN SS 12MM X 40L
21	8	95B58945420000	MHHCS SS M3 X 16L
22	8	95A92169250000	MHHCS SS M6 X 20L
23	1	(VARIOUS)	FRAME EXTRUSION
24	4	95A92034000000	THREADED INSERT M5 X 12L
25	4	95A92169170000	MHHCS SS M5 X 35L
26	4	95A92169280000	MHHCS SS M6 X 35L
27	8	95A92169230000	MHHCS SS M6 X 12L
28	28	95A93724060000	WASHER FLAT SS M6

MEDICAL 75MM PARTS LIST

<u>ITEM</u>	<u>QTY</u>	<u>PART NUMBER</u>	<u>DESCRIPTION</u>
1	1	1LD93364000000	SPROCKET, MED RITE-LINK
2	1	2LC92030000000	PLATE, MED DRIVE END
3	1	2LD91794007002	SHAFT INP DE, RITE-LINK 40/40MM DIA
4	4	95A92166030000	PULL DOWEL PIN SS 6MM X 25L
5	20	95A92169260000	MHHCS SS M6 X 25L
6	1	1LD93348000000	SIDE PLATE SET, MED RITE-LINK
7	2	1LB93478000000	SPACER, MED RITE-LINK
8	2	86A91903000000	FLANGE BEARING, MED RITE-LINK
9	8	95B63342040000	MHHCS SS M14-2 X 35L
10	2	1LC93354000000	SIDE PLATE, LH DRIVE END
11	2	1LC93355000000	SIDE PLATE, RH DRIVE END
12	2	1LD93374000000	GUARD - SS, DRIVE END RITE-LINK
13	14	95A92137010000	T-SLOT NUT - SS, M6
14	2	1LD93115000000	GUIDE BAR, RITE-LINK DRIVE SIDE
15	4	2LA92939000000	LINK SUPPORT, RITE-LINK
16	8	95A67856100000	THREADED INSERT, SS M3 X 6.5L
17	4	95A92170190000	MSHCS SS M6 X 20L
18	(VARIES)	1L SLINK-MED	LINK ASSEMBLY 75MM MED RITE-LINK
19	4	95A92169700000	MHHCS SS M12 X 35L
20	1	95A92743980000	DOWEL PIN SS 12MM X 40L
21	8	95B58945420000	MHHCS SS M3 X 16L
22	8	95A92169250000	MHHCS SS M6 X 20L
23	1	(VARIOUS)	FRAME EXTRUSION
24	4	95A92034000000	THREADED INSERT M5 X 12L
25	4	95A92169170000	MHHCS SS M5 X 35L
26	4	95A92169280000	MHHCS SS M6 X 35L
27	8	95A92169230000	MHHCS SS M6 X 12L
28	28	95A93724060000	WASHER FLAT SS M6

INDUSTRIAL 115MM PARTS LIST

<u>ITEM</u>	<u>QTY</u>	<u>PART NUMBER</u>	<u>DESCRIPTION</u>
1	1	2LD92396000000	SPROCKET, IND RITE-LINK
2	1	2LC92391000000	PLATE, IND DRIVE END
3	1	2LD92397007002	SHAFT INPUT DE, RITE-LINK 40/40MM DIA
4	4	95A92166030000	PULL DOWEL PIN SS 6MM X 25L
5	24	95A92169260000	MHHCS SS M6 X 25L
6	1	2LD92395000000	SIDE PLATE SET, IND RITE-LINK
7	2	2LB92405000000	SPACER, IND RITE-LINK
8	2	86A92426000000	FLANGE BEARING, IND RITE-LINK
9	8	95B63342040000	MHHCS SS M14-2 X 35L
10	2	2LC92043000000	SIDE PLATE, LH DRIVE END
11	2	2LC92044000000	SIDE PLATE, RH DRIVE END
12	2	2LD93445000000	GUARD - SS, DRIVE END RITE LINK
13	20	95A92137010000	T-SLOT NUT - SS, M6
14	2	2LD92938000000	GUIDE BAR, RITE-LINK DRIVE SIDE
15	4	2LA92939000000	LINK SUPPORT, RITE-LINK
16	8	95A67856100000	THREADED INSERT, SS M3 X 6.5L
17	6	95A92170200000	MSHCS SS M6 X 25L
18	(VARIES)	2L SLINK-IND	LINK ASSEMBLY 115MM IND RITE-LINK
19	4	95A92169700000	MHHCS SS M12 X 35L
20	1	95A92743980000	DOWEL PIN SS 12MM X 40L
21	8	95B58945420000	MHHCS SS M3 X 16L
22	12	95A92169250000	MHHCS SS M6 X 20L
23	1	(VARIOUS)	FRAME EXTRUSION
24	4	95A92034000000	THREADED INSERT M5 X 12L
25	4	95A92169170000	MHHCS SS M5 X 35L
26	4	95A92169280000	MHHCS SS M6 X 35L
27	8	95A92169230000	MHHCS SS M6 X 12L
28	36	95A93724060000	WASHER FLAT SS M6

MEDICAL 115MM PARTS LIST

<u>ITEM</u>	<u>QTY</u>	<u>PART NUMBER</u>	<u>DESCRIPTION</u>
1	1	2LD91790000000	SPROCKET, MED RITE-LINK
2	1	2LC92030000000	PLATE, MED DRIVE END
3	1	2LD91794007002	SHAFT INP DE, RITE-LINK 40/40MM DIA
4	4	95A92166030000	PULL DOWEL PIN SS 6MM X 25L
5	24	95A92169260000	MHHCS SS M6 X 25L
6	1	2LD92038000000	SIDE PLATE SET, MED RITE-LINK
7	2	2LB92047000000	SPACER, MED RITE-LINK
8	2	86A91903000000	FLANGE BEARING, MED RITE-LINK
9	8	95B63342040000	MHHCS SS M14-2 X 35L
10	2	2LC92043000000	SIDE PLATE, LH DRIVE END
11	2	2LC92044000000	SIDE PLATE, RH DRIVE END
12	2	2LD93445000000	GUARD - SS, DRIVE END RITE-LINK
13	20	95A92137010000	T-SLOT NUT - SS, M6
14	2	2LD92938000000	GUIDE BAR, RITE-LINK DRIVE SIDE
15	4	2LA92939000000	LINK SUPPORT, RITE-LINK
16	8	95A67856100000	THREADED INSERT, SS M3 X 6.5L
17	6	95A92170200000	MSHCS SS M6 X 25L
18	(VARIES)	2L SLINK-MED	LINK ASSEMBLY 115MM MED RITE-LINK
19	4	95A92169700000	MHHCS SS M12 X 35L
20	1	95A92743980000	DOWEL PIN SS 12MM X 40L
21	8	95B58945420000	MHHCS SS M3 X 16L
22	12	95A92169250000	MHHCS SS M6 X 20L
23	1	(VARIOUS)	FRAME EXTRUSION
24	4	95A92034000000	THREADED INSERT M5 X 12L
25	4	95A92169170000	MHHCS SS M5 X 35L
26	4	95A92169280000	MHHCS SS M6 X 35L
27	8	95A92169230000	MHHCS SS M6 X 12L
28	36	95A93724060000	WASHER FLAT SS M6

150MM CAMCO RITE-LINK CONVEYOR

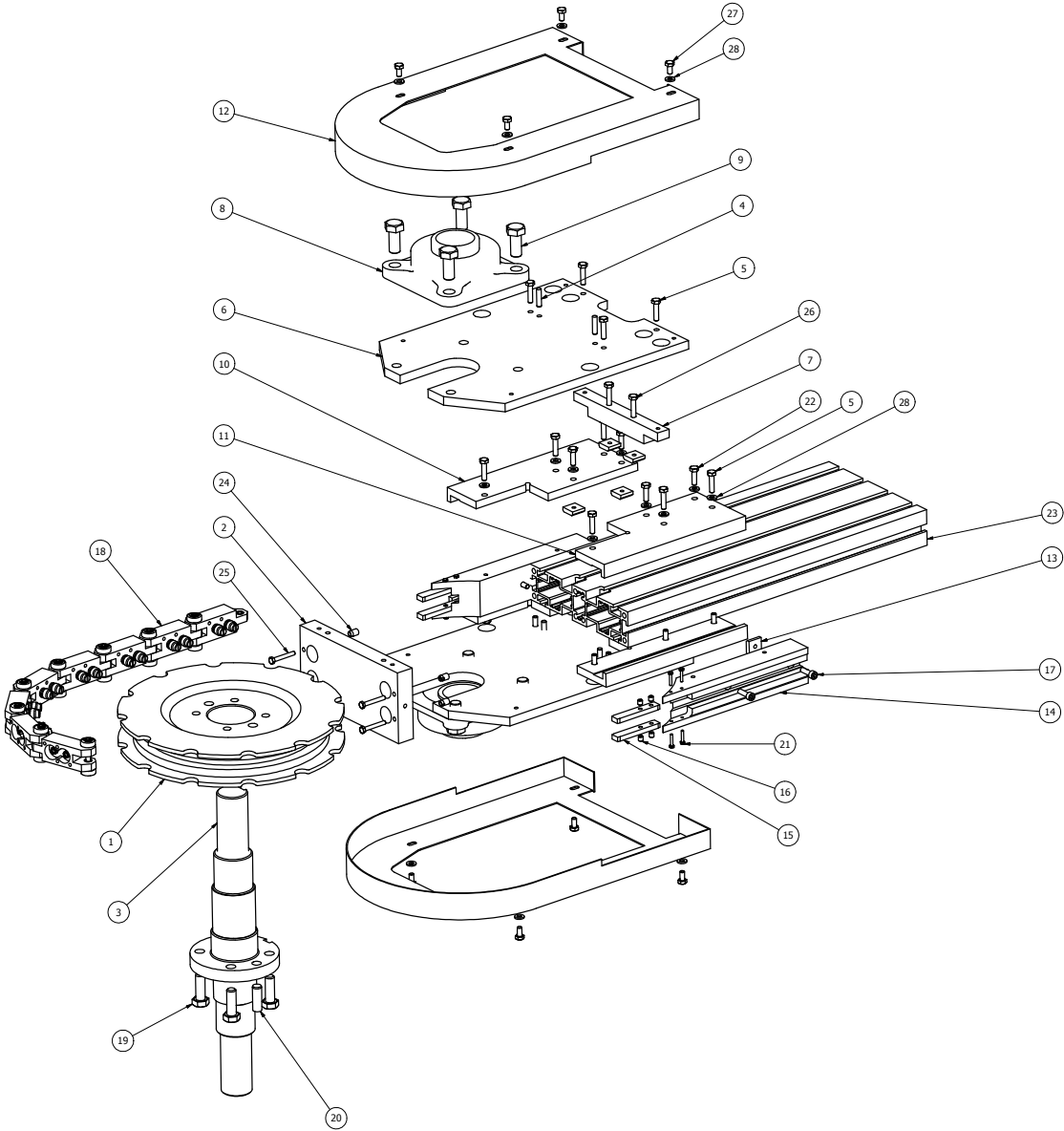

INDUSTRIAL 150MM PARTS LIST

<u>ITEM</u>	<u>QTY</u>	<u>PART NUMBER</u>	<u>DESCRIPTION</u>
1	1	3LD93065000000	SPROCKET, IND RITE-LINK
2	1	2LC92391000000	PLATE, IND DRIVE END
3	1	2LD92397007002	SHAFT INPUT DE, RITE-LINK 40/40MM DIA
4	4	95A92166030000	PULL DOWEL PIN SS 6MM X 25L
5	20	95A92169260000	MHHCS SS M6 X 25L
6	1	2LD92395000000	SIDE PLATE SET, IND RITE-LINK
7	2	2LB92405000000	SPACER, IND RITE-LINK
8	2	86A92426000000	FLANGE BEARING, IND RITE-LINK
9	8	95B63342040000	MHHCS SS M14-2 X 35L
10	2	3LC93086000000	SIDE PLATE, LH DRIVE END
11	2	3LC93085000000	SIDE PLATE, RH DRIVE END
12	2	3LD93095000000	GUARD - SS, DRIVE END RITE LINK
13	14	95A92137010000	T-SLOT NUT - SS, M6
14	2	3LD92898000000	GUIDE BAR, RITE-LINK DRIVE SIDE
15	4	3LA93047000000	LINK SUPPORT, RITE-LINK
16	4	95A67856100000	THREADED INSERT, SS M3 X 6.5L
17	4	95A92170200000	MSHCS SS M6 X 25L
18	(VARIES)	3L SLINK-IND	LINK ASSEMBLY 150MM IND RITE-LINK
19	4	95A92169700000	MHHCS SS M12 X 35L
20	1	95A92743980000	DOWEL PIN SS 12MM X 40L
21	4	95B58945420000	MHHCS SS M3 X 16L
22	8	95A92169250000	MHHCS SS M6 X 20L
23	1	(VARIOUS)	FRAME EXTRUSION
24	4	95A92034000000	THREADED INSERT M5 X 12L
25	4	95A92169170000	MHHCS SS M5 X 35L
26	4	95A92169280000	MHHCS SS M6 X 35L
27	8	95A92169230000	MHHCS SS M6 X 12L
28	28	95A93724060000	WASHER FLAT SS M6

MEDICAL 150MM PARTS LIST

<u>ITEM</u>	<u>QTY</u>	<u>PART NUMBER</u>	<u>DESCRIPTION</u>
1	1	3LD93064000000	SPROCKET, MED RITE-LINK
2	1	2LC92030000000	PLATE, MED DRIVE END
3	1	2LD91794007002	SHAFT INP DE, RITE-LINK 40/40MM DIA
4	4	95A92166030000	PULL DOWEL PIN SS 6MM X 25L
5	20	95A92169260000	MHHCS SS M6 X 25L
6	1	2LD92038000000	SIDE PLATE SET, MED RITE-LINK
7	2	2LB92047000000	SPACER, MED RITE-LINK
8	2	86A91903000000	FLANGE BEARING, MED RITE-LINK
9	8	95B63342040000	MHHCS SS M14-2 X 35L
10	2	3LC93086000000	SIDE PLATE, LH DRIVE END
11	2	3LC93085000000	SIDE PLATE, RH DRIVE END
12	2	3LD93095000000	GUARD - SS, DRIVE END RITE-LINK
13	14	95A92137010000	T-SLOT NUT - SS, M6
14	2	3LD92898000000	GUIDE BAR, RITE-LINK DRIVE SIDE
15	4	3LA93047000000	LINK SUPPORT, RITE-LINK
16	4	95A67856100000	THREADED INSERT, SS M3 X 6.5L
17	4	95A92170200000	MSHCS SS M6 X 25L
18	(VARIES)	3L SLINK-MED	LINK ASSEMBLY 150MM MED RITE-LINK
19	4	95A92169700000	MHHCS SS M12 X 35L
20	1	95A92743980000	DOWEL PIN SS 12MM X 40L
21	4	95B58945420000	MHHCS SS M3 X 16L
22	8	95A92169250000	MHHCS SS M6 X 20L
23	1	(VARIOUS)	FRAME EXTRUSION
24	4	95A92034000000	THREADED INSERT M5 X 12L
25	4	95A92169170000	MHHCS SS M5 X 35L
26	4	95A92169280000	MHHCS SS M6 X 35L
27	8	95A92169230000	MHHCS SS M6 X 12L
28	28	95A93724060000	WASHER FLAT SS M6

NOTES

NOTES



A **DOVER** COMPANY

Automation
Robohand *FERGUSON*
CAMCO

CAMCO & FERGUSON Products
1444 South Wolf Road
Wheeling, IL 60090
USA
Ph: 847-459-5200
Toll-free: 800-645-5207
Fax: 847-459-3064
camco@destaco.com
www.camcoindex.com

ISO 9001:2000 Registered

DE-STA-CO Headquarters
1025 Doris Road
Auburn Hills, MI 48326
USA
Ph: 248-836-6700
Toll-free: 1-888-DESTACO (337-8226)
Fax: 248-836-6740
Toll-free fax: 800-682-9686
marketing@destaco.com
www.destaco.com

DE-STA-CO Europe
Germany
+49-6171-705-0
europe@destaco.com

DE-STA-CO Asia
Thailand
+66-2-326-0812
info@destaco.com

DE-STA-CO South America
Brazil
0800-124070
samerica@destaco.com