

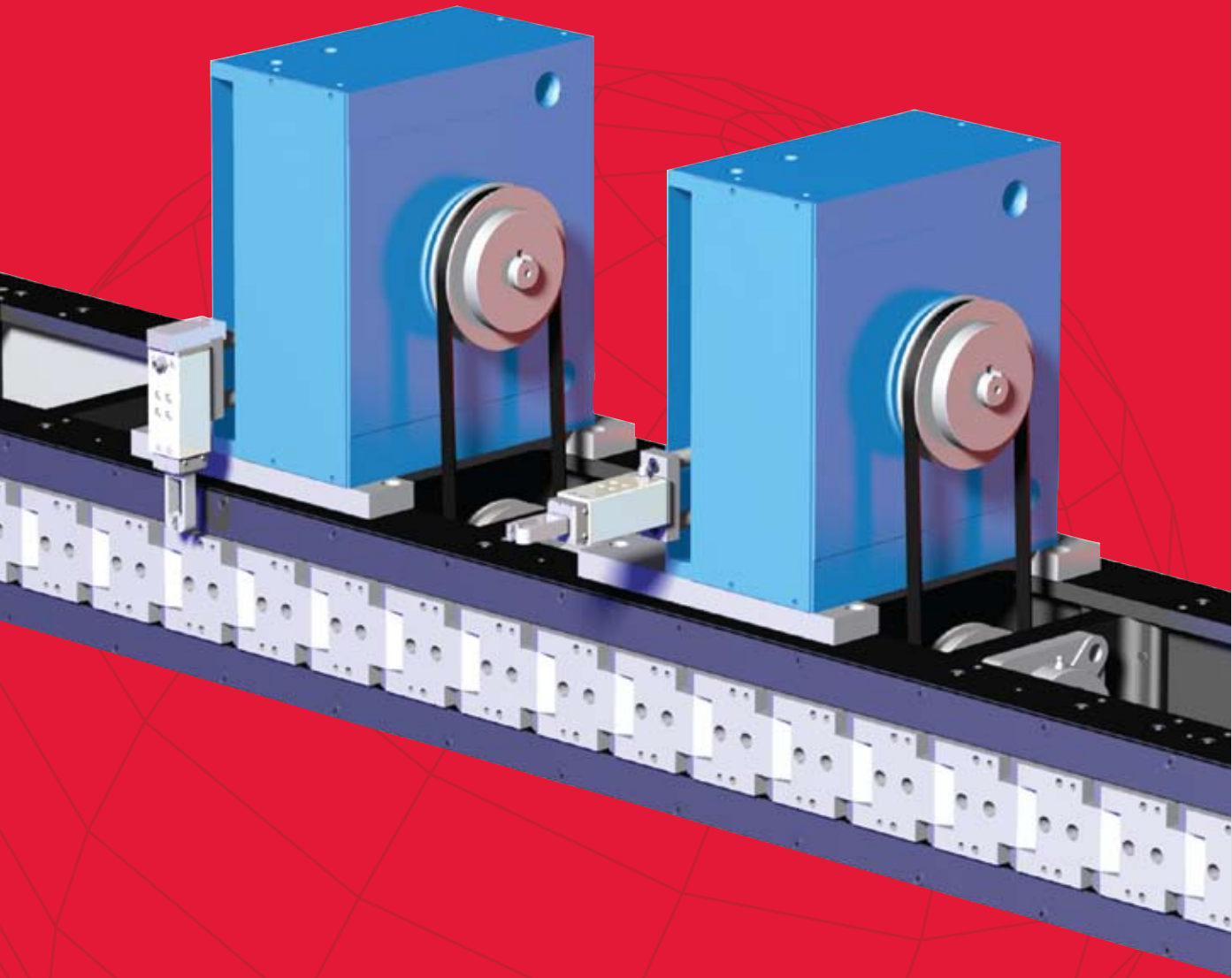

Automation
Robohand FERGUSON
CAMCO

CAMCO CAMBOT LINEAR PARTS HANDLERS



One Source, Complete Solution

www.destaco.com
Precisely positioning our customers for productivity

One Source, Complete Solution

Benefits

CAMCO Cambot® Linear Parts Handlers, combined with other DE-STA-CO products, offer a low maintenance, cost-effective solution for a complete parts handling package.

- **New, cost effective design** for low-cost operation
 - Reliable CAMCO mechanical cam design
 - Lubed for Life
- **Easy integration** with other DE-STA-CO products for one-stop shopping
 - Camco Modular Precision Link Conveyors and Ring Drives
 - DE-STA-CO Vacuum products
 - Robohand Direct Connect™ Grippers (no adapter plates) and E-Gripper
- **Customized** for your application
 - Input shaft available on either side for ease of integration
 - Line shaft drive or gear reducer and motor drive package for synchronous or asynchronous operation
 - Standard or custom strokes and timing designed for your specific requirements

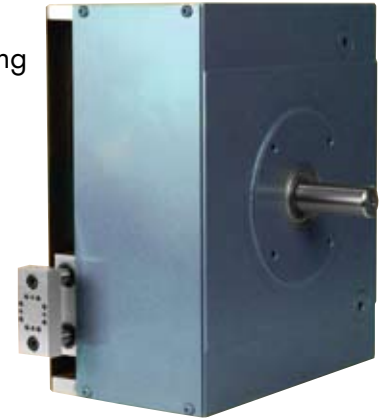

Applications

Automated production systems with small parts transfer such as consumer products, electronics, and medical device assembly and test.

Technical Specifications

Model	Maximum Lift	Maximum Transfer	Capacity at 30 rpm	Capacity at 60 rpm
M90	50 mm	90 mm	3.6 kg (8 lbs)	2.3 kg (5 lbs)
M100	65 mm	100 mm	8 kg (18 lbs)	3.6 kg (8 lbs)
M150	75 mm	150 mm	18 kg (40 lbs)	9 kg (20 lbs)
M250	75 mm	250 mm	22.6 kg (50 lbs)	9 kg (20 lbs)

Model	Lift		Transfer	
	Accuracy	Repeatability	Accuracy	Repeatability
M90 / M100	±.13 mm (±.005")	±.03 mm (±.001")	±.08 mm (±.003")	±.03 mm (±.001")
M150 / M250	±.20 mm (±.008")	±.08 mm (±.003")	±.08 mm (±.003")	±.03 mm (±.001")

Contact your Sales Representative for sizing & selection assistance

CAMBOT® LINEAR PARTS HANDLERS

M90/M100/M150/M250

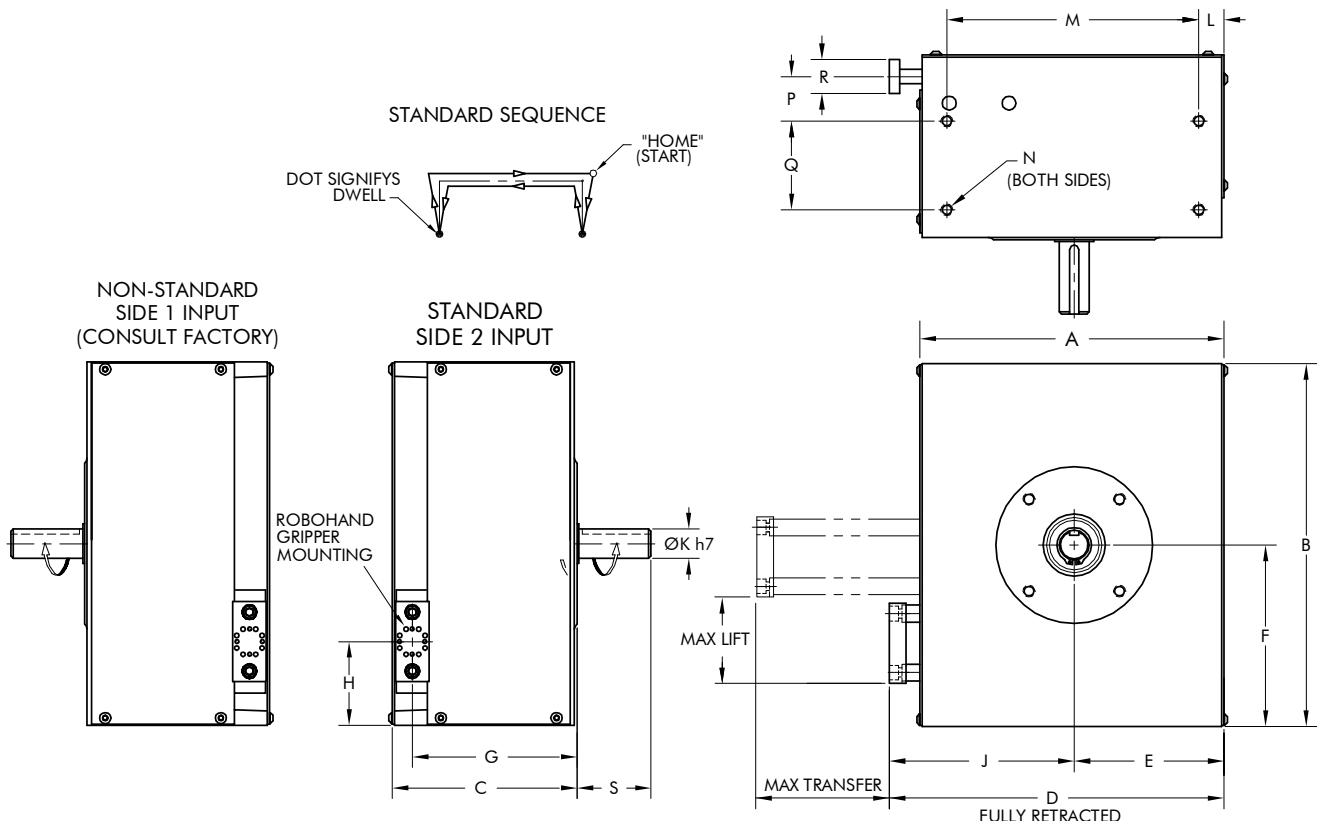

Dimensions (mm)

	M90	M100	M150	M250
A	205	251	332	470
B	245	290	400	545
C	125	145	170	213
D	234	279.7	366	520
E	101	123	160	230
F	123	145	200	285
G	111	130	148	186
H	56.8	65	90	104.8
J	133	157	206	290
K	20	25	30	40
L	17	12	15	20
M	170	225	300	425
N	4 x M8	4 x M8	4 x M10	4 x M12
P	30	40	40	28
Q	60	65	80	120
R	25.4	25.4	51	114
S	50	50	55	80

All dimensions are subject to change. For actual dimensions, please request the current drawing from CAMCO

GRIPPER MOUNTING BLOCK

Linear Parts Handler Output Gripper Mounting Block Dimensions

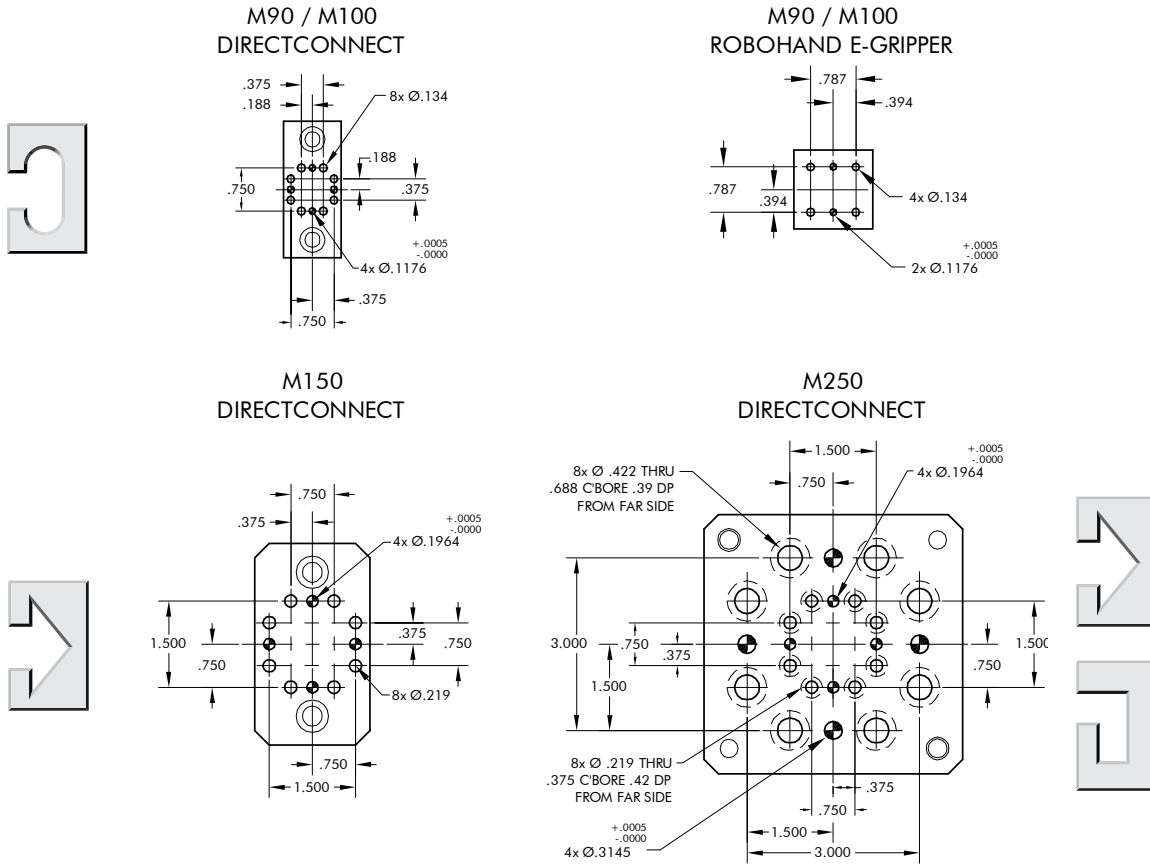

Robohand DirectConnect Grippers & Rotaries

Consult the DE-STA-CO Automation Catalog or your local sales representative for information about these items.

Model	E-Gripper	DPDS/DPDL	DPG	DPP	DPW	DCT	DRF
M90 / M100	RPE-100M RPE-101M	DPDS-047M DPDS-056M DPDL-047M DPDL-056M	N/A	DPP-10M-06 DPP-10M-12 DPP-14M-15 DPP-14M-25	DPW-250M-1 DPW-250M-2	DCT-12M DCT-16M DCT-20M	N/A
M150	N/A	DPDS-088M DPDS-125M DPDL-088M DPDL-125M	DPG-10M-1 DPG-10M-2 DPG-10M-3 DPG-10M-4	DPP-20M-25 DPP-20M-28 DPP-28M-31 DPP-28M-50	DPW-375M-1 DPW-375M-2 DPW-500M-1 DPW-500M-2	DCT-25M	DRF/DRG-075M DRF/DRG-094M DRF/DRG-106M
M250	N/A	DPDS-175M DPDS-250M DPDL-175M DPDL-250M	DPG-10M-1 DPG-10M-2 DPG-10M-3 DPG-10M-4	DPP-20M-25 DPP-20M-28 DPP-28M-31 DPP-28M-50	DPW-375M-1 DPW-375M-2 DPW-500M-1 DPW-500M-2	DCT-25M	DRF/DRG-075M DRF/DRG-094M DRF/DRG-106M

All dimensions are subject to change. For actual dimensions, please request the current drawing from CAMCO

ORDERING PROCEDURE

Contact your Sales Representative for sizing & selection assistance

Customer Name: _____ Date: _____

1. Specify Linear Parts Handler Model and Strokes _____

Lift Stroke _____ mm Transfer Stroke _____ mm

Standard Strokes: Lift (mm) x Transfer (mm)			
M90	M100	M150	M250
10 x 20	15 x 100	15 x 150	25 x 250
30 x 90	45 x 100	45 x 150	55 x 250
50 x 20	65 x 20	75 x 50	75 x 170
50 x 60	65 x 60	75 x 110	75 x 210
50 x 90	65 x 100	75 x 150	75 x 250

2. Specify Output Sequence:

Standard Custom (specify sequence)

3. Select Mounting Position:

1 2 3 4 5 6

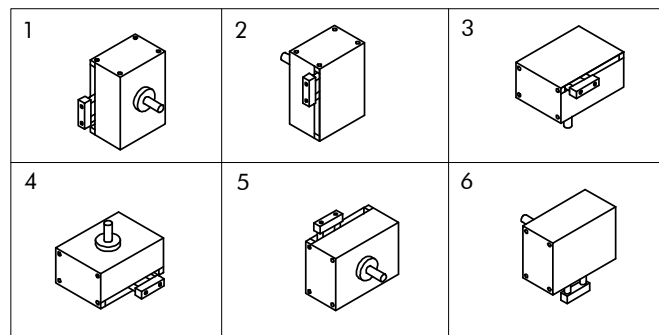
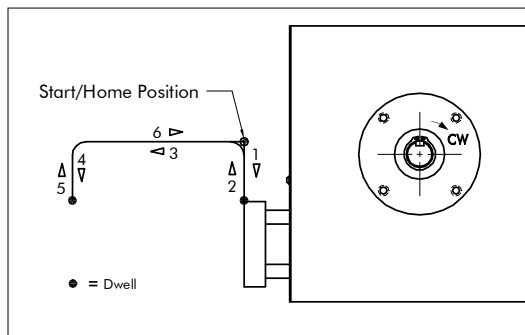

4. Select Drive Package: Gear Reducer, Motor, AC Drive

Model	Gear Reducer	AC Motor	1 hp AC Drive Input Voltage (select 1)		
<input type="radio"/> M90	<input type="radio"/> R180	<input type="radio"/> 1/3 hp	<input type="radio"/> 120 VAC	<input type="radio"/> 240 VAC	<input type="radio"/> 480 VAC
<input type="radio"/> M100	<input type="radio"/> R180	<input type="radio"/> 1/3 hp	<input type="radio"/> 120 VAC	<input type="radio"/> 240 VAC	<input type="radio"/> 480 VAC
<input type="radio"/> M150	<input type="radio"/> R225	<input type="radio"/> 3/4 hp	<input type="radio"/> 120 VAC	<input type="radio"/> 240 VAC	<input type="radio"/> 480 VAC
<input type="radio"/> M250	<input type="radio"/> R225	<input type="radio"/> 1 hp	<input type="radio"/> 120 VAC	<input type="radio"/> 240 VAC	<input type="radio"/> 480 VAC

5. Select Reducer Mounting. For Example: A-2-LH

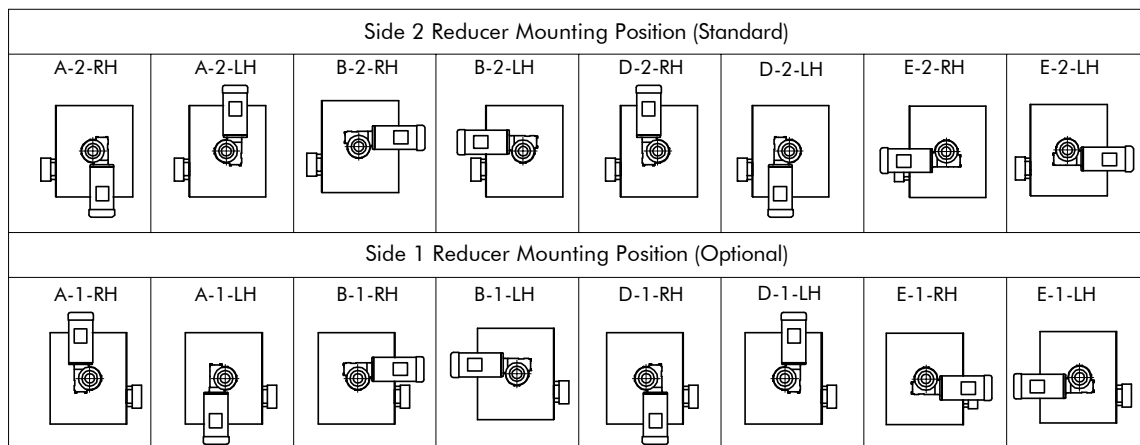



A DOVER COMPANY

PRECISELY POSITIONING OUR CUSTOMERS FOR PRODUCTIVITY.

Workholding

- Widest variety of workholding products
- High durability and reliability
- Flexible solutions for all applications
- Custom products for unique requirements

Automation

- Broad range of engineered automation products
- Complementary products for modular integration
- Unmatched accuracy, reliability and performance
- Unparalleled global sales, service and engineering support

DE-STA-CO GLOBAL LOCATIONS

NORTH AMERICA

DE-STA-CO Headquarters
 Auburn Hills, Michigan
 Tel: 1.248.836.6700
 Marketing: marketing@destaco.com

Auburn Hills, Michigan
 Tel: 1.888.DESTACO
 Customer Service: cs-workholding@destaco.com
cs-automation@destaco.com

Wheeling, Illinois
 Tel: 1.800.645.5207
 Customer Service: camco@destaco.com

Charlevoix, Michigan
 Tel: 1.888.DESTACO
 Customer Service: cs-automotive@destaco.com

Red Wing, MN (Central Research Laboratories)
 Tel: 651.385.2142
 Customer Service: sales@centres.com

SOUTH AMERICA

Brazil
 Tel: 0800-124070
 Customer Service: samerica@destaco.com

ASIA

Thailand
 Tel: +66-2-326-0812
 Customer Service: info@destaco.com

China
 Tel: +86-21-5423-4435
 Customer Service: china@destaco.com

India
 Tel: +91 80 41123421-426
 Customer Service: india@destaco.com

EUROPE

Germany
 Tel: +49-6171-705-0
 Customer Service: europa@destaco.com

France
 Tel: +33-1-3996-5000
 Customer Service: france@destaco.com

UK
 Tel: +44-1902-797980
 Customer Service: uk@destaco.com

Spain
 Tel: +34-936361680
 Customer Service: spain@destaco.com

Netherlands
 Tel: +31-297285332
 Customer Service: benelux@destaco.com



A DOVER COMPANY

Automation

Robohand FERGUSON
CAMCO

CAMCO Products

1444 South Wolf Road
 Wheeling, IL 60090
 Phone: 1.847.459.5200
 Fax: 1.847.459.3064
 Email: camco@destaco.com

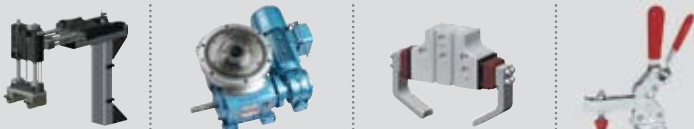

Precisely positioning our customers for productivity.

© Copyright, 2008 DE-STA-CO. All rights for layout, photos and text rest with the publisher DE-STA-CO. All photomechanical or other reproductions only with our express permission.

SKU 0007-07/09